



FLIGHT SYSTEMS

207 Hempt Rd. Mechanicsburg PA 17050

Phone: 717-590-7330 • Fax: 717-590-7327

www.flightsystems.com

Printed in USA - Revised Jan. 2013

MODEL 826

Replacement For Onan®

P/N 305-0826

Voltage Regulator



**NOTICE: READ PG. 5 "PRE-INSTALLATION
MAINTENANCE" BEFORE INSTALLING
YOUR MODEL 826 REGULATOR**

USER MANUAL



FLIGHT SYSTEMS

207 Hempt Rd. Mechanicsburg PA 17050

Phone: 717-590-7330 • Fax: 717-590-7327

www.flightsystems.com

TABLE OF CONTENTS

- Model 826 Features 1
- Mounting Diagram 2
- Description 3
- Pre-Installation Maintenance 5
- Specifications 6
- Footprint Diagram 7
- Plug Pin Diagram 7
- Warranty Information 8
- Other Products & Services 9

OTHER PRODUCTS & SERVICES

NEW UNITS - Flight Systems sells Improved Replacements for these Onan® Controls, some of which are no longer offered by the Mfg:

OEM Part #	Description
ONAN® 300-C859	GEN SET CONTROL
ONAN® 300-0679/80	ENGINE CONT. MNTR.
ONAN® 300-0681/82	ENGINE CONT. MNTR.
ONAN® 300-B1073, B944	RV GEN SET CONTROL
ONAN® 300-1006/1404/1540	YD REGULATOR
ONAN® 300-2604, 2605	ENGINE MONITOR
ONAN® 300-2784, 2943	RV GEN SET CONTROL
ONAN® 300-3056, 3687, 3950	RV GEN SET CONTROL
ONAN® 300-3763, 5268	RV GEN SET CONTROL
ONAN® 300-3764, 5342	RV GEN SET CONTROL
ONAN® 300-4296, 300-4297	ENGINE MONITOR
ONAN® 300-4901, 4902	RV GEN SET CONTROL
ONAN® 300-4320, 300-4923	RV GEN SET CONTROL
ONAN® 300-4456, 300-5299	RV GEN SET CONTROL



If you service ONAN® RV GEN SETS you need to meet the “G-MAN”! - Is the problem with the control board, the regulator, the windings or other components? The G-MAN can tell you, saving hours of tedious guesswork! Available adapters allow testing of dozens of Emerald, Marquis, Microlite & Camp Power models.

The SLICK STICK Keeps your gen set properly maintained -- cleans and re-finishes slip rings quickly and safely!



POINT-MAN - Flight Systems’ newest RV Generator Service Tool! The Point-MAN simply plugs in between the generator and the regulator giving you easy access to eight key circuits needed for effective regulator troubleshooting.

REBUILDING SERVICE - Flight Systems rebuilds over 200 different Onan®, Kobler®, Generac®, Basler®, ASCO® and other Generator & ATS Controls. Please call or see our website for a complete list.

WARRANTY INFORMATION

Note: Always Refer to the Specific Generator Set Manual when Troubleshooting Problems.

The Model 305 Generator Voltage Regulator is warranted to be free from defects in materials and workmanship for a period of two years from the date it was sold. *(This date appears on unit label)*

Flight Systems' Limited Warranty covers the repair or replacement of defective product within the warranty period. It does not cover the cost of installation, or removal costs incurred, or possible damage to other equipment (including the generator or parts thereof) as a result of the Model 305 Generator Voltage Regulator.

Flight Systems (or its authorized agent) shall reserve the right to determine the cause of malfunction.

In the case if we determine that it was due to abuse, misuse, improper installation, acts of nature, failure to perform recommended gen set maintenance procedure or problems elsewhere in the gen set, the warranty claim shall be disallowed and established repair rates shall apply. Alteration of the unit in the field will also void warranty.

Ship defective units directly to:

**FLIGHT SYSTEMS
207 Hempt Rd.
Mechanicsburg PA 17050
Attention: Warranty Service**

Please prepay all freight charges and note the nature of the failure, if known.

Return Policy: Unwanted items may only be returned within 30 days of original purchase date. Refund/credit issued shall be less a 25% per item restocking/re-test fee as long as unit is in new, undamaged condition. Shipping charges are not refundable.

MODEL 826 FEATURES

The Flight Systems Model 826 was designed as a direct replacement for Onan P/N 305-0826. It is an exact fit and requires no modification. The Model 826 is a metal-cased regulator used in all Marquis models (BGM and NHM series). Note: Refer to the specific Onan service manual for your model when servicing these generators.

Flight Systems has been repairing and building replacement generator controls for over 35 years. The Model 826 continues our tradition of designing and building products which will not only perform exactly as the original, but offer improvements in operation and longevity. See Page 9 for our other products & services.

Model 826 Regulator Features Include:

1. Rugged packaging
2. Weather proof cast aluminum housing
3. Improved resistance to summer heat
4. Designed for long life
5. Latest technology
6. Loads protected from under frequency
7. Loads protected from overvoltage on overspeed
8. Cost-Effective replacement
9. Ease of installation; cut out for socket wrench
10. Full Two Year Warranty

NOTICE: If preventative maintenance procedures (see gen set owners manual and "Pre-Installation Maintenance" on pg. 5 of this manual) have not been performed prior to installing this regulator, damage can result - such damage is NOT covered under warranty!

MODEL 826 MOUNTING DIAGRAM



MOUNTING

The voltage regulator is mounted on the end of the generator housing by means of the existing Onan bracket (305-0825-02) and two bolts. Hold the regulator with the harness facing the front. The upper bolt goes through the regulator and bracket into the threaded hole in the housing. The lower bolt goes through the regulator directly into the bracket. Cutouts in the sides of the case provide access for a socket wrench. While mounting the regulator, it is important to route the harness and plug under the end of the generator housing and up through the slot in the control compartment. The black sleeve over the harness protects it from abrasion.

MODEL 826 FOOTPRINT DIAGRAM

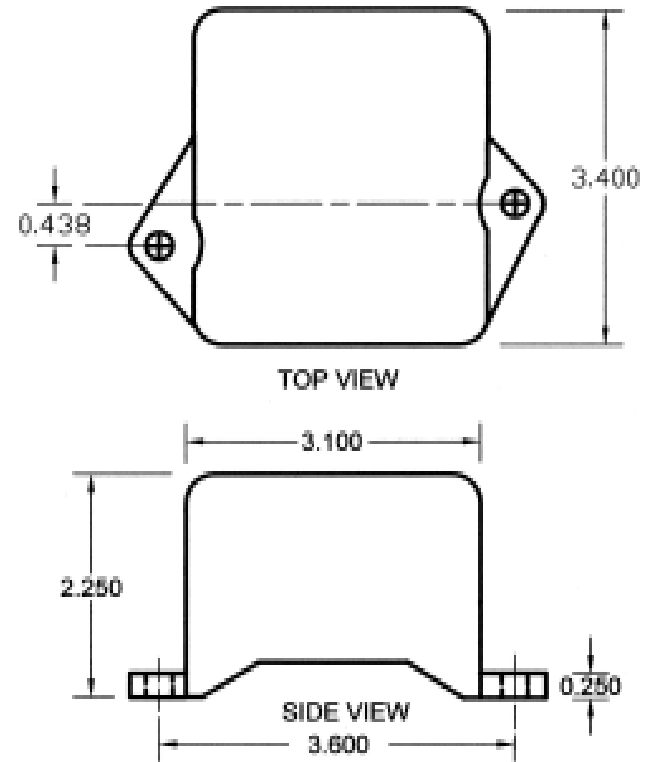

MODEL 826 PLUG PIN DIAGRAM (Front View of Plug)

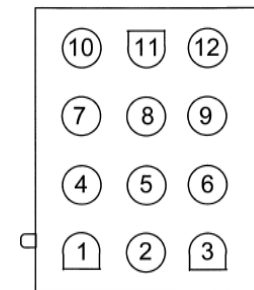

SPECIFICATIONS

- BATTERY VOLTAGE:** Voltage 12 VDC +/- 2 V.
- FIELD:** Voltage Range 20-75 VDC, Nominal. Peak 160 V.
Current 6 A continuous, peak 15 A at 175° F.
Field Flash 12 VDC with 12.7 VDC battery.
- FREQUENCY RANGE:** 45-65 Hz, Nominal 60 Hz.
Voltage ramps down with frequency.
(See Table Below)
- VOLTAGE REGULATION:** 120 V +/- 2 V. No load to full load.
- OPERATING TEMPERATURE RANGE:** To 175° F.
- ISOLATION TO CASE:** Greater than 10 Meg. Case is grounded.
- ENVIRONMENTAL CHARACTERISTICS:** Unit has a metal case and is intended to be mounted inside of electrical enclosure.
- RELATIVE HUMIDITY:** 0 - 95 percent.
- VIBRATION:** Vibration Resistant Package.
- SIZE:** See Footprint Diagram, Page 7.

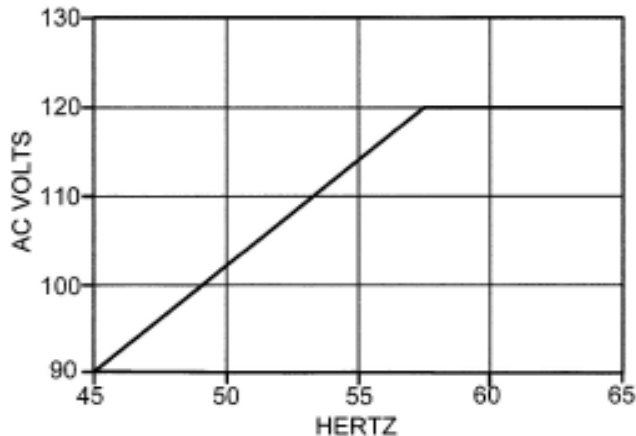

REGULATED VOLTAGE VS. FREQUENCY

DESCRIPTION

OVERVIEW

The Model 826 regulates the voltage output of your generator. By constantly monitoring the voltage and frequency output at the stator, the Model 826 effectively responds with the proper corrective action, even under the most drastic load change. To protect loads, voltage is automatically lowered during underfrequency operation. The Model 826 is rugged, weather-proof and heat resistant.

FIELD FLASH VOLTAGE “J4-7”

When starting the generator set, a DC voltage is applied to J4 pin 7 of the voltage regulator from the control P.C. Board assembly (P1-5 on 300-3056/3590 or P1-3 on 300-3764). This supplies field current from J4 pin 9 (F1+), through the rotor to J4 pin 10 (F2-).

QUADRATURE WINDING “J4-11 and 12”

When the engine starts, the generator supplies AC voltage from the quadrature winding (stator) of the generator to the voltage regulator J4 pin 11 (Q1), and J4 pin 12 (Q2). This AC voltage is rectified to a DC voltage, and is applied to the rotor from J4-9. The voltage regulator also looks at the frequency of this AC voltage, and makes any necessary corrections to the rotor current.

FIELD DRIVE “J4-10”

The function of J4-10 is to provide the proper current to the rotor under varying load conditions. It does this by switching on and off rapidly (120 times per second). The “on” time is varied to supply the proper field current. This current is maintained during the “off” time by a free-wheeling diode in the regulator.

•Continued on Page 4

DESCRIPTION (Cont.)

VOLTAGE SENSE “J4-2 and 3”

When the engine starts, the generator supplies AC voltage to the voltage regulator J4 pin 2 (L1), and J4 pin 3 (L0). The voltage regulator looks at the amplitude of this AC voltage, and makes any necessary corrections to the field current. During operation, applying or adding loads to the generator decreases the voltage on the sensing terminals. The voltage regulator will then increase the DC field current, thereby offsetting the voltage drop. When loads are removed (decreasing load) the reverse is true. Continuously adjusting the field current as load changes is how voltage regulation is achieved.

VOLTAGE ADJUSTMENT “J4 Pins 1, 4 and 5”

J4- (1 and 4) are tied together internally in the voltage regulator and J4-5 is connected to the internal return of the voltage regulator. For 60 Hz, an external jumper is connected between J4-4 and J4-5; for 50 Hz a potentiometer is connected here. J4-1 is not used. (*Refer to Generator Manual*).

FRAME GROUND “J4-8”

The regulator case is connected to frame ground by means of J4 pin 8. This connection serves as a safety ground to insure that the regulator case is at ground potential at all times, in addition to the ground provided by means of the mounting bolts.

WIRE HARNESS

An eight inch long pigtail harness, from the voltage regulator to the plug, is provided. The wire is automotive #18 AWG with SLX insulation designed to withstand vibration and high temperature. Each wire is stamped J1-1 thru J1-12. The black wire is on J1-1. A special PVC coated fiberglass jacket protects the harness from abrasion.

PRE-INSTALLATION MAINTENANCE

Important: It is necessary to perform certain maintenance items prior to installing a new regulator. Failure to perform this maintenance will void the warranty and may result in the premature failure of the new regulator.

ENGINE

The engine must be in good running condition so that it can supply the necessary horsepower to the generator under full load. The governor must be set at so that the engine runs at the proper RPM (for 60 Hz, 4-pole, 1800 RPM; 2-pole, 3600 RPM). The governor must not be surging, even at no load (slight surging is normal on cold start-up but should go away after a minute or so). A dirty or gummed up carburetor will cause surging. The electric automatic choke must be operating properly so that it does not stick or fail to open, thereby causing the engine to run excessively rich. If any of these problems exist, they must be corrected before installing the new regulator. Refer to the applicable Onan service manual for your model for engine servicing details.

GENERATOR

Checking the rotor DC resistance is particularly important before installing a new regulator. This is your chance to find out if there is a problem that possibly caused the last regulator to fail. Unplug regulator. Measure the resistance between pins 9 and 10 on the connector that plugs into the regulator. It should be between 23 and 28 ohms. A reading much lower than 23 ohms indicates a partial short in the rotor. A reading much higher than 28 ohms indicates a problem with the brushes, slip rings or a bad connection. The most likely cause will be dirty or oxidized slip rings so check them first and clean if necessary (**See Slick Stick, Pg. 9**). If the resistance is still high, check the brushes and connections. If possible, check the stators for grounds (**See G-MAN, pg. 9**). Make sure that the field flash voltage is reaching the regulator by measuring 12 VDC on pin 7 to frame ground during cranking. No voltage indicates a control board or wiring problem.