

VR448

Generator Automatic Voltage Regulator

Operation Manual

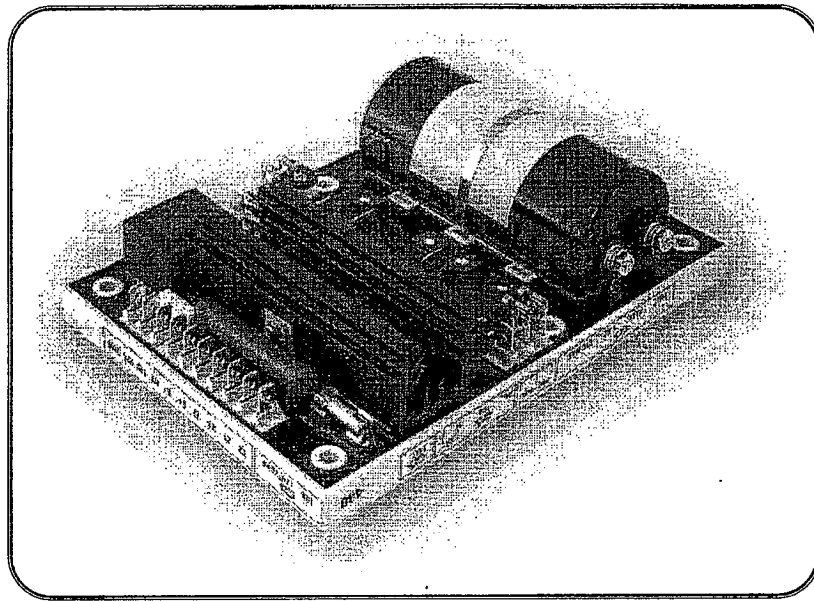

Permanent Magnet Generator or A.R.E.P. or Auxiliary Winding Type
Compatible with LEROY SOMER R448*

* Use for reference purposes only - not a genuine LEROY SOMER product.

SPECIFICATIONS

Normal AVR supply power: 2 auxiliary windings (X1, X2, and Z, Z2)

Shunt supply : 150V - 50/60Hz

Rated overload current: 10A, 10s.

Electronic built-in (overload, short circuit, and loss of sensing) protection: If excitation current raises over 10 Amps for more than 10 seconds, excitation current will drop automatically to about 1A.

To reset AVR protection, generator must be stopped (or by cutting supply voltage to the AVR).

Protection of power inputs by fuses F1

Voltage sensing: 5VA insulated transformer with input voltage taps at:

Terminals 0-110V = 95 to 140V

Terminals 0-220 V = 170 to 260 V

Terminals 0-380 V = 340 to 520V

Output Voltage adjustment by using pot P2

Other sensing voltages by using an adapting other transformers

Current sensing (parallel operation) CT 2.5 VA class 1 secondary current xxx/1 (optional).

Adjustment of quadrature droop with pot P1

Under-speed (U/F) and LAM protection: for knee frequency adjustable use P4.

Excitation over current adjustment use P5: 4.5 to 10A

For 50/60 Hz (U/F) selection use jumper ST3.

Load acceptance module

LAM is suppressed by cutting wire marked ST5

LAM (Load Acceptance Module) function.

When applying a step load to the generator, the rotational speed (frequency) of the genset drops. If the speed is below the preset frequency, the "LAM" circuits drops the voltage about 15% and this way reducing the effective step to about 25%, as long as the speed has not recovered to normal values.

The "LAM" is used either to reduce the speed drop of the engine, during the step load, or to increase the applicable step load for the same speed variation (turbo charged engines) so the engine can recover normal speed quickly.

To prevent voltage oscillations, the frequency threshold must be adjusted about 2 Hz below the lowest frequency in normal operation.

Optional items for use with the AVR

CT for parallel operation with other generators

Remote voltage adjusting potentiometer 470 ohm .3W (*) giving an adjustment range of +/- 5% (centering of the range by using internal P2 potentiometer). Remove wire ST4 to connect external potentiometer.

Three phase sensing available by using additional modulo Model R 730:200 to 500V. Cut ST1 to connect this module.

Generator output voltage is adjusted by using the voltage adjustment potentiometer on the AVR

Power factor regulator (2nd function) and voltage equalization before paralleling with the mains (3rd function)

CT xxx/1 A. 5VA CL1

Module R 724: 2 functions.

Module R 725 A: 3 functions.

EMI suppression

(*)Note: For a wider voltage adjustment range and 1 k ohm/3W pot may be used.

The R 730 module is not compatible with paralleling.

Special applications

Field de-energizing

Cutting excitation current is accomplished by switching off the supply power to AVR (1 lead on each auxiliary winding)

Contacts capacity: 10A. 250V AC

This is the same connection used to reset internal protection of AVR.

Static test AVR

* Testing the A.V.R. by using a static test does not necessarily mean it can operate properly.

* But inversely, if the A.V.R. does not test properly during static tests, it is obviously defective

Setup the test (see drawing).

Supply voltage must be 100 to 140V and the light bulb must be rated for 220v use you can also use 2 x 110v bulbs in series.

Total lamp load must not exceed 100 Watt

1) - Adjust AVR voltage by moving screw P2 to maximum CCW position

2) - Apply power to the AVR the lamp should flash momentarily and turn off.

3) - Slowly rotate the AVR voltage screw clockwise:

The bulb will slowly light up and reach full brilliance before P2 is moved completely clockwise, at the regulating point a small movement back and forth with P2 will turns the bulb on and off. If the lamp remains constantly on/off the AVR is defective.

Repeat the test supplying AVR power through terminals X1, X2, and then test again by supplying power through terminals Z1, Z2.

Static test LAM

(under-speed protection)

Voltage adjustment Pot P2 should be set in it normal position just when the lamp just begins to glow. Turn P4 slowly CCW the brightness should decrease suddenly the voltage at AVR's output terminals E+, E- must falls about 15%. Then resetting P4 to initial position : the lamp should glow normally as before

PMG excitation system

With **PMG** excitation, a permanent magnet generator (PMG) added to the alternator supplies the AVR with voltage which is independent of the main alternator winding. This is fitted at the rear of the machine and connected to the R 448 AVR, and the ST9

jumper must be disconnected.

These two principles provide the machine with a short-circuit current capacity of 3 IN for 10 s, and good immunity to distortions generated by the load.

The AVR monitors and corrects the alternator output voltage by adjusting the excitation current.

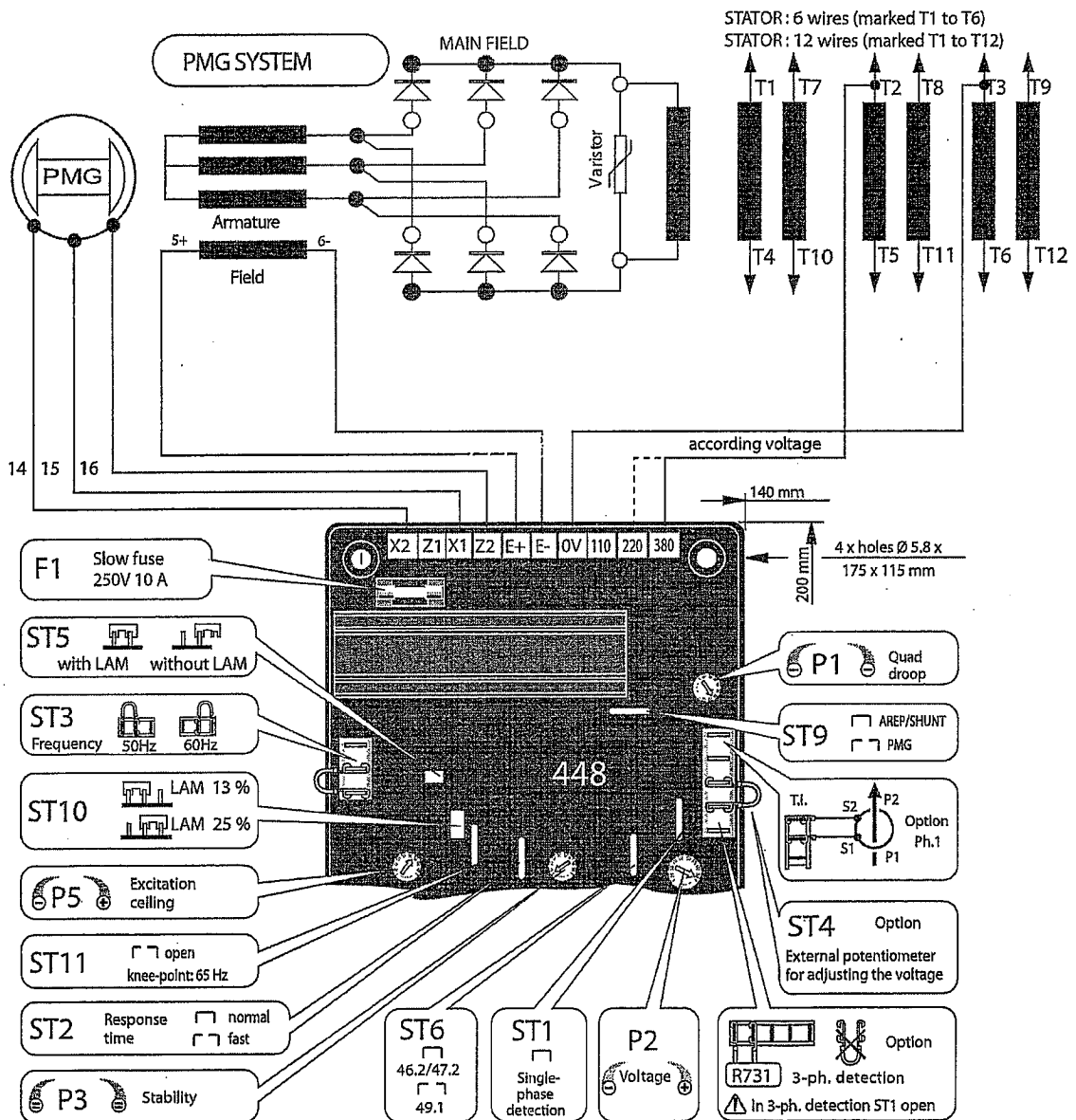

SHUNT or separate excitation system

In SHUNT excitation, R 448 A.V.R. is supplied by main windings (140V - 50/60 Hz) to X1, X2.

The new functions are :

- Parallel operation between alternators with C.T.
- Parallel operation with the mains with C.T. and R 726 module

- 3-phase sensing (R 731 module)
- LAM function integrated in the R 448 AVR.

In this case of LSA 42.2, A.V.R. and module(s) must be installed in the external control panel.

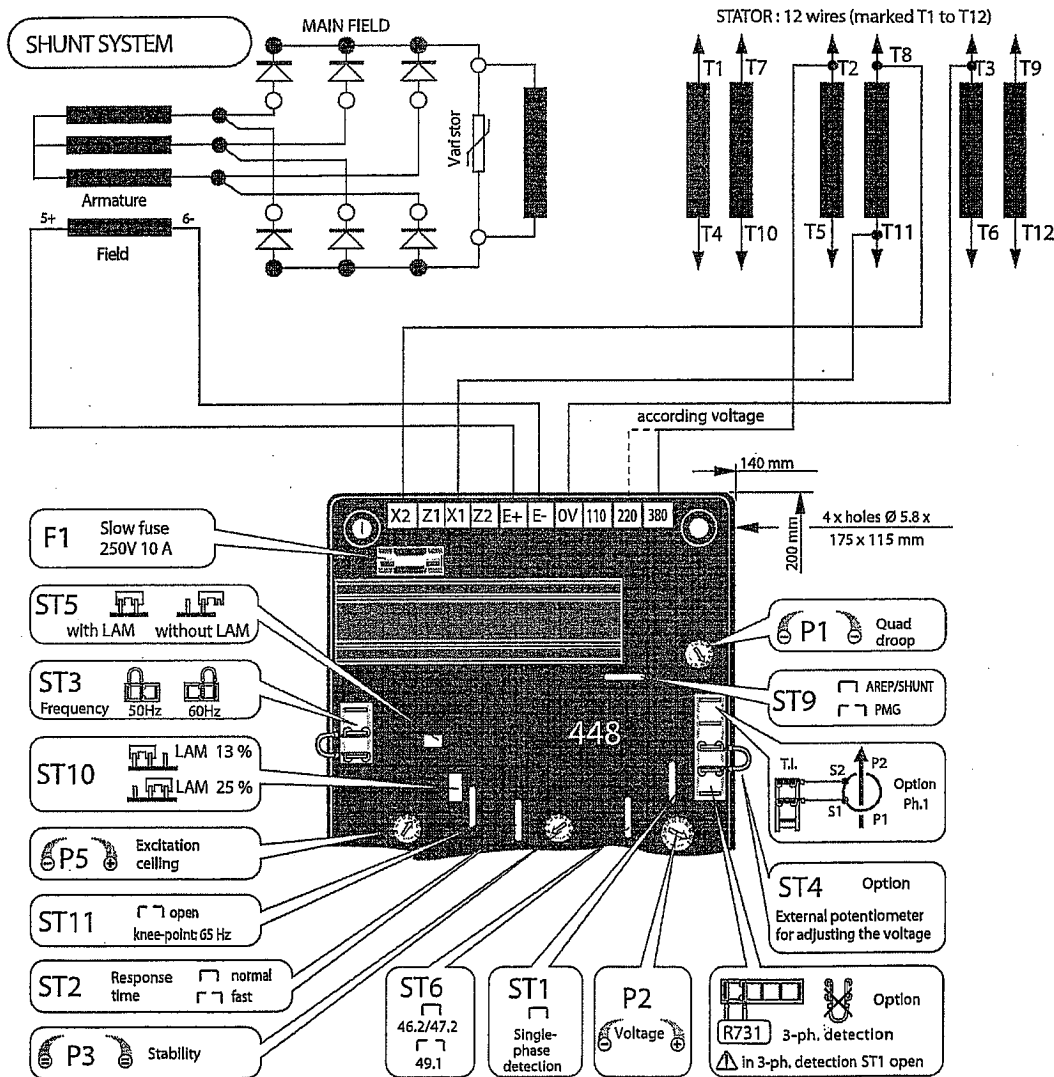

Adjustment procedure

- a) Initial setting of potentiometers
- P2 VOLTAGE: lowest fully CCW.
 - P3 STABILITY: middle position.
 - PI QUADRATURE VOLTAGE DROP : fully CCW
 - P5 EXCITATION CURRENT LIMIT: to be adjusted only if necessary maximum fully CW.
 - Remote voltage trimmer Rhe - 470 OHM (jumper ST4 removed): middle position.
- b) Connect one analog (needle type) voltmeter cal. 50V D.C. across E+, E-terminals and another (300V-500V or 1000V) A.C. across the alternator output terminals.
- c) Make sure that the 50/60 Hz link is correctly connected
- d) (P2) potentiometer must be set maximum anti-clockwise
- e) (P4) (V/Hz) must be set maximum clockwise
- f) (P3) (Stability) has to be adjusted maximum clockwise -1/3.
- g) Start and adjust the engine speed corresponding to 48Hz for 50 Hz (nominal) or 58 for 60 Hz.
- h) Adjust output voltage with (P2) to the required value
- rated voltage UN if generator operates alone
(for example 400V)
 - or UN+2 to 4% for parallel operation with CT
(i.e. 410V - see below)
- If voltage is unstable, adjust (P3) (try in both directions), noting voltage across E+, E- (approx.10V dc) The fastest recovery time may be achieved when (P3) is set close to the limit of instability. If there is no stable position try adjustment again after having cut or reconnecting link ST2 (normal / fast).
- i) Turn (P4) anticlockwise until the voltage drops about 15%
- j) Modify engine speed around 48 or 58 Hz in order to check the LAM voltage drop (~ 15%).
- k) Readjust speed of genset to its normal no-load level

ADJUSTMENTS IN PARALLEL OPERATION

Note: Preliminary to any adjustment on the AVR, make sure that engine speeds are similar.

- l) Presetting for parallel operation (with CT connected to terminals S1 ,S2 of terminal strip J2)
- Potentiometer P1 (Voltage droop) in middle position. Switch on the rated load (P.F. 0.8 inductive). The output voltage should drop 2% to 3%. If voltage rises, reverse the 2 leads from the CT.
- m) No load voltages must be identical on all gensets working together and in parallel.
- Synchronize and parallel the gensets together.

- By adjusting engine speed, reduce power exchange, to 0 KW
- By adjusting voltage pot (P2 or Rhe) on one of the machines try to cancel (or minimize) circulating currents.
- Do not change voltage adjustments.
- n) Switch on the load (adjustments cannot be made if there is no reactive load).
- By adjusting speed, balance the KW (proportionally to the rated powers of each genset).
- By adjusting voltage droop with pot. P1, balance the output currents.

Adjustment of maximum excitation current (Excitation ceiling)

- Static adjustment of excitation current limitation, potentiometer P5 (factory adjustment: 10 A, fuse caliber: 10A-10seconds).

The factory adjustment corresponds to the excitation current for a sustained 3 phase short circuit, of about 3 times the rated current, unless otherwise specified(*)

It is possible to reduce the maximum excitation level by a static method which is safer for the alternators and the network.

Disconnect the supply leads (X1 X2, Z1, Z2) and sensing leads (0-110-220-380) on the AVR. Connect the supply as shown (X1, X2, 0,110V). Connect an ammeter (10A, dc) in series with the exciter field. Turn P5 fully CCW. Switch on the supply. If there is no output current from AVR, turn P2 (voltage) clockwise until ammeter indicates a stabilized current.

Switch the supply off, then on again. Turn P5 clockwise until the required current is obtained in the exciter field, (limit to 10A)

Checking internal protection:

Switch off (B): the excitation current must rise to the pre-set high level, and remain at this level for a period of more than 10 seconds, than fall to less than 1A.

To reset, switch off the supply by opening switch (A).

Note: After having adjusted the excitation current limitation

(*): In many countries short-circuit current equal to 3 times IN is obligatory in order to allow selective tripping of circuit breakers.

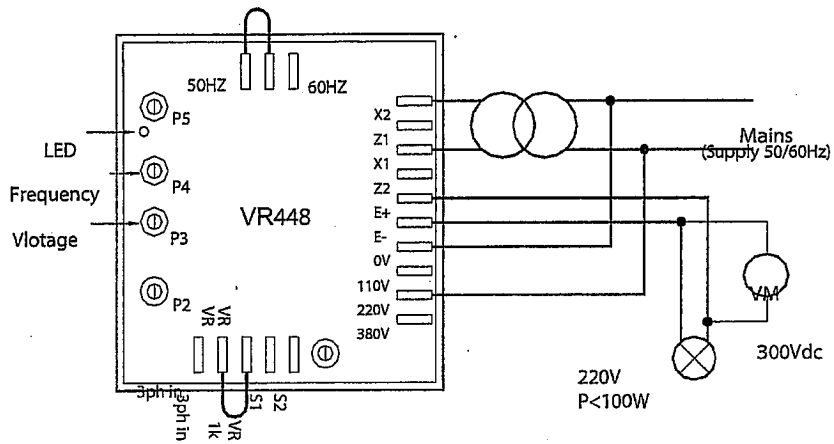
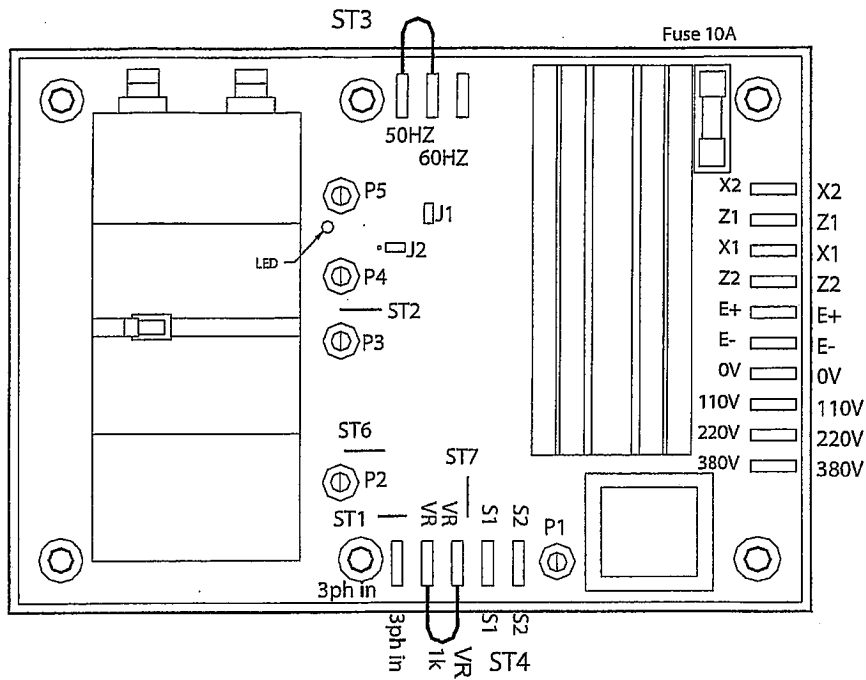

Static test AVR

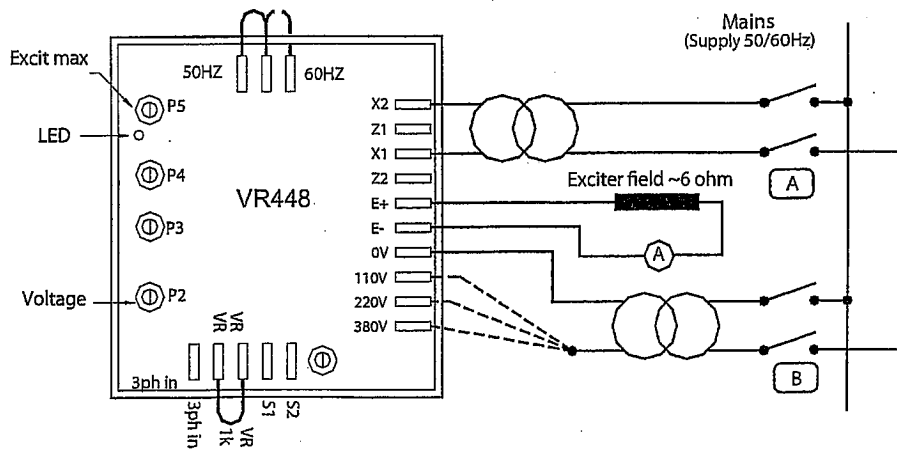

Adjustment of maximum excitation current

AREP excitation system

For both AREP & PMG excitation systems, the alternator voltage regulator is the R 448.

With AREP excitation, the R 448 electronic AVR is powered by two auxiliary windings which are independent of the voltage match circuit.

The first winding has a voltage in proportion to that of the alternator (characteristic Shunt), the second has a voltage in proportion to the stator current (compound characteristic: Booster effect).

The power supply voltage is rectified and filtered before being used by the AVR monitoring transistor.

