

MODEL 612 SEAWATER FLOW MONITOR MANUAL



FLIGHT SYSTEMS

505 Fishing Creek Road Lewisberry, PA 17339 USA

717-932-9900

Fax: 717-932-9925

www.flightsystems.com

TABLE OF CONTENTS

PURPOSE -----	1
APPLICATION -----	1
UNIQUE FEATURES -----	1
PRINCIPLE OF OPERATION -----	2
Sensor -----	2
Logic Unit -----	2
Remote Display -----	2
INSTALLATION -----	2
Minimum and Full Installation -----	2
Installing the Adapter -----	3
Selecting the Tee Location -----	3
Installing the Tee in the Seawater Intake Line -----	3
Installing the Sensor -----	4
Installing the Sensor Cable -----	4
Installing the Logic Unit -----	4
Installing the Remote Display -----	4
Sensor Wiring -----	4
Remote Display Wiring -----	4
Analog Output Wiring -----	5
Event Output Wiring -----	5
Alarm Output Wiring -----	5
Power Wiring -----	5
ADJUSTMENT	
Immersion Requirements -----	5
Location of Adjustments -----	5
Effect of Adjustments -----	5
Offset Adjustment -----	6
Span Adjustment -----	6
Constant Speed vs. Variable Speed Velocities -----	6
Setting an Alarm for Constant Speed Applications -----	6
Setting an Alarm for Variable Speed Applications -----	6
MAINTENANCE -----	6
TROUBLESHOOTING -----	7
Troubleshooting Chart -----	7
Voltage Charts -----	8
Sensor Test -----	9
Display Test -----	9

CHARTS and ILLUSTRATIONS

CHARTS

1 - Tee Installation Dimensions -----	3
2 - Troubleshooting -----	7
3 - Logic Connector Voltage -----	8
4 - Single Remote Display Voltage -----	8
5 - Dual Remote Display Voltage -----	8
6 - Sensor Test -----	9

ILLUSTRATIONS

Fig. A - Parts Identification -----	10
Fig. B - Installation of Adapter into Tee -----	11
Fig. C - Selecting a Location for the Tee -----	11
Fig. D - Tee Mounting Positions -----	12
Fig. E - Installing Sensor into Adapter -----	12
Fig. F - Logic Unit Wiring Diagram -----	13
Fig. G - Logic Unit Wiring Diagram (W/Engine Saver) -----	14
Fig. H - Dual Remote Display Wiring Diagram -----	15
Fig. I - Adjustment of Span & Offset -----	15
Fig. J - Mounting Template for Optional Single Remote Display -----	16
Fig. K - Mounting Template for Optional Dual Remote Display -----	16
Fig. L - Setting Alarm Switches -----	17
Fig. M - System Configuration, Model 612 With Single Remote Display -----	18
Fig. N - System Configuration, Model 612 With Dual Remote Display -----	19

PARTS -----	20
SERVICE -----	21
WARRANTY -----	22

PURPOSE

The purpose of the Model 612 Seawater Flow Monitor is to monitor the flow through the seawater side of heat exchangers and to give a constant indication of the flow relative to the normal flow under nominal operating conditions. Any significant reduction in flow due to a restriction or a pump failure can be immediately seen visually and alarmed, if desired. The ability to constantly monitor seawater flow gives the operator or Captain an early warning of a loss of cooling capacity and to what extent. This information can be evaluated and acted upon well in advance of actual engine overheating. The unit is not intended to measure flow rate quantitatively in gallons/minute.

APPLICATION

The Model 612 is applicable to both main and auxiliary engines, diesel or gasoline fueled, using a heat exchanger or raw seawater for cooling. It may be used to protect constant-speed engines, such as those used on air conditioners and generators, or variable-speed engines used for propulsion in conventional or Z-drive applications. It may be used as a stand-alone unit or in conjunction with the Model 550 Engine Saver®, the Model 565 Engine Controller, the Model 555 Auxiliary Alarm Monitor, or other alarm systems and/or annunciator panels. This version of the Model 612 operates from 24-28 VDC power, however a 12-volt version is available.

UNIQUE FEATURES

The flow sensor probe has no moving parts and is very resistant to fouling. It protrudes only a small distance into a special tee that is installed in the seawater intake line. The flow monitor is applicable to hoses of 1 inch to 3 inches inside diameter. All wetted parts are made of marine-grade stainless steel to prevent corrosion. The Model 612 logic unit has its own bar graph display, however an optional remote display is also available. For dual applications, such as a pair of main engines, two logic units can be connected to one dual remote display. Refer to the PARTS section of this manual for details and ordering information for the various components of the Model 612.

SUMMARY OF FEATURES

- **Suitable for main or auxiliary engines**
- **All solid state with no moving parts**
- **For hoses from 1 to 3 inch I.D.**
- **Wetted parts are marine-grade stainless steel**
- **Removable anti-fouling sensor probe**
- **Built-in engine room bar graph display**
- **Remote single or dual bar graph displays**
- **Auto-dimming for all lighting conditions**
- **Programmable alarm and event outputs**
- **Analog output for data collection**
- **Self testing with failure warning**
- **Easy installation and adjustment**

PRINCIPLE OF OPERATION

Sensor

The Model 612 is somewhat unique among marine seawater flow monitors in that it has no moving parts. This is the secret to its superior anti-fouling and low-maintenance characteristics. The sensor probe operates on a differential-temperature principle. It contains a small, low-power heater (0.27 watts), which produces a slight rise in temperature above the ambient temperature of the seawater. When there is no flow, the probe body surface temperature equalizes, and its internal temperature sensors all see the same temperature. When there is flow (velocity), the tip of the probe is cooled by the moving water. A temperature sensor located near the tip of the probe sees a greater temperature drop than the ones located in the body of the probe. This temperature difference increases with increasing flow (velocity) and causes a slight change in the resistance of the various sensor elements within the probe.

Logic Unit

The sensor information, in the form of resistance changes, is received and interpreted by the logic unit. The logic unit is normally located in an engine room within 16 feet of the flow sensor. The logic unit displays the information as a series of ten segments or bars on a blue bar graph. More bars illuminated means more flow. Ten bars illuminated means that the flow is at its normal maximum, or greater. No bars illuminated means that the flow is zero, or less than the threshold of sensing.

The flow (velocity) is represented by an analog output voltage of 0 to 5 volts that is available for operating a remote display or for supplying flow information to a data collection system such as the Model 575 Service Advantage. If desired, an alarm may be set to activate if the flow drops below a selected number of bars, from 1 to 10.

The operation of the model 612 is fail-safe. The continuity of the sensor and its wiring is constantly monitored. An open circuit condition on any of the five wires within the sensor cable or a failure in the sensor itself is immediately detected and causes the display and the alarm to flash.

Remote Display

An optional remote display is available that gives the same bar graph indications as the logic unit at a remote location such as a wheelhouse, bridge, or engineer's control station.

The remote display can be located up to 200 feet away from the logic unit. The remote bar graph display has an automatic dimming feature that senses the ambient light level and adjusts the brightness of the display to a comfortable non-distracting level.

INSTALLATION

Minimum and Full Installation

A minimum installation consists of an appropriately sized tee, hose clamps (not supplied), an adapter, a sensor probe, a sensor cable and a logic unit. Refer to Figure A, pg. 10. A full installation adds a remote display and its wiring. Remote displays are available in single or dual versions. In a dual installation, two sensors and two logic units can each have single remote displays, or can share a dual remote display. Other optional features such as an alarm annunciator, event output and/or data collection can be connected if desired. Refer to the PARTS section of this manual for details and ordering information for the various components of the Model 612 Seawater Flow Monitor.

Installing the Adapter

Refer to Figure B, pg. 11. The adapter has a standard ½” NPT pipe thread (tapered) on the large end. Apply a good grade of Teflon sealing compound (not tape) to this end only and thread it into the port in the tee. **CAUTION:** The threads of the adapter are sharp and may cause personal injury without careful handling. Tighten securely using a 17mm open-end wrench on the “flats” of the adapter. If this is not available, use an adjustable wrench.

DO NOT use a pipe wrench. The other end of the adapter is machined to accept the O-ring seal on the sensor. **DO NOT** apply any compound on this end.

Selecting the Tee Location

Select a location for the tee in a section of hose that runs horizontally rather than vertically between the seawater intake and the heat exchanger inlet. (A vertical section could theoretically be used, but it would have to meet all the other criteria and it would have to be full of water at all times, guaranteed). There must not be any bends or changes in cross-section for at least 5 hose diameters upstream and 3 hose diameters downstream. For example, a 3-inch hose needs to have at least 15 inches of constant cross-section upstream of the sensor and 9 inches downstream. This is to ensure that the flow at the sensor is relatively undisturbed and is *laminar* rather than *turbulent*. Turbulent flow will cause erratic indications. Refer to Figure C, pg. 11. Ideally, there should also be a shut-off valve in the line between the hull seawater intake and the tee. This valve can be closed during installation of the tee and subsequent inspection of the sensor.

CHART 1 - TEE INSTALLATION DIMENSIONS

Hose I.D. inches	Length of hose To remove, in.	Minimum Distances, inches		Tee P/N
		Upstream	Downstream	
1.00	3.50	5.00	3.00	57-6120-04
1.25	3.25	6.25	3.75	57-6120-05
1.50	3.00	7.5	4.5	57-6120-06
2.00	2.75	10.0	6.00	57-6120-07
2.50	2.50	12.5	7.5	57-6120-08
3.00	2.50	15.0	9.00	57-6120-09

Installing the Tee in the Seawater Intake Line

Refer to Figure D, pg. 12. When the location of the tee has been determined, remove a section of hose of the appropriate length for the size of the tee as shown in the chart.

Refer to Chart 1 (above). Install the tee in the hose and position the tee so that the port for the sensor is at the side or bottom of the line (not the top). The objective is to always have water in full contact with the probe. If the line is known to always be full, then the side mounting position is preferred because it offers more resistance to fouling. If you are not certain that the line will always be full, then position the sensor port at the bottom of the line. A compromise would be to position the sensor port at a 45-degree angle between the bottom and side positions. In any case, make sure that there is sufficient clearance to install the sensor into the adapter. Secure the tee with clamps.

Installing the Sensor

Refer to Figure E, pg. 12. The sensor has a special O-ring seal and a threaded retaining ring. Do not use any compound when installing the sensor into the adapter. Use a 22mm open-end, box-end or deep socket wrench. If none of these are available, use an adjustable wrench. Tighten snugly but do not over tighten. Remember the O-ring makes the seal, not the threads. The sensor may be easily removed at any time for inspection without disturbing any connections.

Installing the Sensor Cable

Carefully mate the keyed orange sensor cable connector to the sensor and tighten by hand only. Route the cable as necessary to the location chosen for the logic unit being careful to avoid hot objects or sharp edges. The logic module may be located up to 16 feet (5 meters) from the sensor with the standard length cable supplied. The cable length may be extended up to an additional 100 feet if necessary, or a custom cable may be ordered. If the cable must be extended, note the color code on the cable supplied. Use the same colors if possible. If not, mark the logic unit end of the extended cable with tags showing the original colors. If the cable supplied is too long, it may be shortened or simply coiled and secured with wire ties. The latter is recommended in the event that the logic unit would ever have to be re-located for any reason. Support the cable with wire ties as necessary.

Installing the Logic Unit

Make sure that the logic unit is positioned so that there is a clear view of its bar graph display and adequate clearance to access the adjustments on the same end. Also, make sure that the PC board assembly will have enough clearance to be slid out of the case partially to gain access to the alarm programming switches inside, near the display end. See the ADJUSTMENT section. Locate the unit away from hot objects. Mount the unit securely by means of the four holes in the mounting flanges.

Installing the Remote Display

Install the Remote Display (if used) in a suitable location in a panel. A template is provided for both the single and dual displays as a guide for making the required panel cutout. Refer to Figures I and J, both on pg. 16. Either display requires at least 1½ inches of clearance behind the mounting surface for the connector and wiring. A panel of almost any thickness can be accommodated. The single and dual displays are of the same height and depth and can be mounted side-by-side, if desired. The display unit is secured in place by means of four #6 screws (not supplied).

Sensor Wiring

Refer to the Wiring Diagram, Figure F, pg. 13, and secure the five sensor wires from the sensor cable to pins 1 through 5 of the 14-pin plug, observing the color code. Any combination of wrong connections of these five wires to pins 1 through 5 will not damage the sensor or the logic unit but will result in improper operation.

Remote Display Wiring (Optional)

Refer to the Logic Unit Wiring Diagram, Figure F, pg. 13. Connect pins 6,7,8 and 9 of the logic unit to the appropriate wires from the remote display cable. This cable is Alpha Wire P/N 2466C (or equivalent) and contains two #22 AWG shielded pairs and a ground wire. Connect the ground wire to pin 9 at the logic unit end only. One of the pairs (red and black) carries the power and the other pair (green and white) carries the signal to the display. In a dual installation, the dual remote display is connected to two logic units, one feeding each side of the display, such as “Port” and “Starboard”, each with its own cable. Refer to the Dual Remote Display Wiring Diagram, Figure H, pg. 15.

Analog Output Wiring (Optional)

Refer to the Logic Unit Wiring Diagram, Figure F, pg. 13. An optional analog output (0-5V) is available on pin 11 for connection to a data collection system such as the Model 575. Connections should be made with shielded or shielded twisted pair wire to eliminate the possibility of noise pick-up. This output has a series resistance of 100 ohms and is overload protected.

Event Output Wiring (Optional)

Refer to the Logic Unit Wiring Diagram, Figure F, pg. 13. An event and output is available on pin 12 for connection to a data collection system such as the Model 575. A steady level of 5 volts represents a low-flow alarm condition. A level of 0 volts represents a no-alarm condition. A pulsing 5-volt signal represents an open circuit in the sensor or its wiring. This means the same thing as a flashing display. This output has a series resistance of 100 ohms and is overload protected.

Alarm Output Wiring (Optional)

Refer to the Logic Unit Wiring Diagram, Figure F, pg. 13. An alarm output is available on pin 13 for connection to an annunciator panel or device such as an indicator, audible alarm or shutdown relay. This output can also be connected to the AUX 2 input of the Model 550 Engine Saver or one of the six channels of the Model 555 Auxiliary Alarm Monitor. The alarm output is an open circuit normally, and switches to ground (battery negative) on alarm. The alarm device positive terminal is connected to a source of 24 volts, (or pin 14) and its negative terminal is connected to pin 13.

Power Wiring

Refer to the Logic Unit Wiring Diagram, Figure F, pg. 13. Connect pin 10 (NOT pin 9) to power ground and pin 14 to the 24-volt supply. These circuits should be run with AWG #18 wire and protected by a fuse or a circuit breaker preferably rated at 1-2 amps but not more than 5 amps.

ADJUSTMENT

Immersion Requirements

Refer to Figure C, pg. 11. Before attempting adjustment, make sure that there is water in full contact with the sensor. If water is sloshing on and off of the sensor, adjustment will be a thoroughly frustrating experience and will likely be unsuccessful. The water should be at a reasonably constant temperature during adjustment. Changes in water temperature during the procedure will make adjustment more difficult. Under most normal running conditions, the intake water temperature will be almost constant or will vary slowly. The logic unit will automatically compensate for slowly varying water temperature. A rapid decrease in water temperature will result in a false indication of increased flow. Conversely, a rapid increase in water temperature will result in a false indication of decreased flow.

Location of Adjustments

Refer to Figure I, pg. 15. The adjustments are accessed via the holes in the display end of unit marked OFFSET and SPAN. A potentiometer-adjusting tool is preferred, but a small screwdriver will work. NOTE: The SPAN and OFFSET adjustments are 15 turn adjustments without stops at the end, only a faint "click".

Effect of Adjustments

The OFFSET adjustment determines the "zero flow" point on the display. Turning this adjustment CW will cause more bars to light with no flow. The SPAN adjustment determines the sensitivity. Turning this adjustment CW will cause more bars to light with a given rate of flow. The range of the SPAN adjustment is approximately 2:1. Expect some degree of interaction between the two adjustments.

Offset Adjustment

Apply power to the Seawater Flow Monitor. The green POWER indicator on the logic unit should light. Allow at least one minute for the system to stabilize. With the water not moving, (no flow) adjust the OFFSET clockwise until the first bar on the display lights, then CCW until it just goes off. NOTE: If several bars are lit initially, adjust the OFFSET CCW until the first bar just goes off.

ALTERNATE Offset Adjustment: If desired, an alternate means of adjustment is to set the OFFSET so that the first bar is lit with no flow instead of no bars. This is a matter of preference. Please notice that if this method is chosen, approximately 10% of the indicating range *will be given up*. Also, the analog output will be approximately 0.5 volts with no flow instead of 0 volts. This could be a consideration when using a data collection system.

Span Adjustment

With the engine running at what is expected to be full flow, adjust the SPAN as necessary to just light the top bar of the display. Adjusting the SPAN CW will light more bars. NOTE: The display will track *increasing* flow much faster than *decreasing* flow. With the flow back at zero or near zero, re-check the OFFSET adjustment. It will have moved a small amount, depending on how much the SPAN was adjusted. Wait until the display has stabilized at the zero flow condition before re-adjusting the OFFSET. This may take 20 to 30 seconds. This procedure may have to be repeated two or three times to “fine tune” the adjustments.

Constant Speed vs. Variable Speed Velocities

In a constant speed application such as a generator or an air conditioner, the flow will be practically constant at or near the top of the scale, or 10 bars. Generators and air conditioners use smaller diameter seawater lines than main engines and have higher flow velocities. It is usually not a problem to obtain an indication of 10 bars at full flow. In a variable speed application, particularly in large diameter lines with very low velocities, even at full flow, it may not be possible to light all of the bars of the display.

Setting an Alarm for Constant-Speed Applications

If it is desired to use the optional alarm feature, it can be set at 7 or 8 bars for a constant speed application. Refer to Figure L, pg. 17. A lower number could be used for greater tolerance to low flow, but with less protection. This is accomplished by turning “on” the switch corresponding to the desired number of bars for a no-alarm condition. **ONLY ONE SWITCH MUST BE TURNED ON AT A TIME.** If no switches are turned “on”, the alarm is always activated. For example, if switch number 8 is turned “on”, the alarm will activate if the flow falls below 8 bars. This might occur if the seawater intake became partially obstructed.

Setting an Alarm for Variable-Speed Applications

In a variable speed application such as on main propulsion engines, the flow velocity will be lower because of the larger line size and will likely vary over a considerable range from idle to full throttle. It may not be possible or practical to use the optional alarm feature in some cases. If it is used, it may need to be set at a low number of bars, such as 1 or 2, depending on the seawater flow velocity at idle.

MAINTENANCE

The Model 612 Seawater Flow Monitor, by design, is almost maintenance-free. There are no moving parts to stick, jam or wear out. The sensor probe is smooth and protrudes only slightly into the line, which gives it excellent resistance to fouling. All wetted parts are marine-grade stainless steel.

During seasonal routine maintenance of the engines, the sensor probe should be removed and visually inspected to make sure it is clean and in good condition. The probe can be removed from the adapter using a 22mm wrench. A small amount of seawater may flow from the adapter. The adapter can be easily plugged or held with the thumb momentarily while inspecting the probe. For convenience, the seawater shut-off valve can be closed, but this is not absolutely necessary. Replace the probe and tighten snugly. Do not over-tighten. Remember to open the seawater shut-off if it was closed!

TROUBLESHOOTING

Troubleshooting Chart

Refer to Chart 2 below. The most common installation and adjustment problems are covered by this chart. For each SYMPTOM, a PROBABLE CAUSE and SOLUTION is listed.

CHART 2 - TROUBLESHOOTING CHART

SYMPTOM	PROBABLE CAUSE	SOLUTION
Green POWER LED not illuminated.	Fuse blown or circuit breaker tripped.	Check 24 volt power at pins 9 (GND) and 14 (+24)
	Loose or wrong connections.	
One or more bars illuminated with no flow.	OFFSET set too high.	Adjust OFFSET CCW.
No bars illuminated at any flow.	OFFSET set too low.	Adjust OFFSET CW.
10 bars illuminated at less than full flow.	SPAN set too high.	Adjust SPAN CCW.
Less than 10 bars illuminated at full flow.	SPAN set too low.	Adjust SPAN CW.
Two or more bars light simultaneously or a gap appears between bars.	More than one alarm switch "ON"	Turn only one alarm switch "ON" at a time.
Alarm activated even with 10 bars illuminated.	No alarm switches turned "ON"	Turn "ON" one alarm switch.
Display flashes.	Logic unit connector not seated.	Push connector on firmly.
	Sensor connector not seated.	Mate connector properly.
	Wrong sensor connections.	Check connections.
	One or more sensor wires open.	Repair/replace as needed.
	Defective sensor.	Replace sensor.
Little or no response to flow regardless of adjustments.	Wrong sensor connections.	Check connections.
	Sensor not fully immersed in water.	Rotate or re-locate tee.
	Defective logic unit.	Replace logic unit.
Remote display does not show the same number of bars as the logic unit.	Wrong or loose connections between the logic unit and the remote display.	Check remote display connections at both ends of the cable.
	Defective remote display.	Replace remote display.
Remote display does not light at all.	Wrong or loose connections between the logic unit and the remote display.	Check remote display connections at both ends of the cable.
	Defective remote display.	Replace remote display.
Right side of dual remote display does not dim.	No logic unit connected to the left side of dual remote display.	Connect logic unit to left side of display.

Voltage Charts

A Voltage Chart is provided to verify the correct voltages at the logic unit connector and the remote display connectors. These charts aid in fault locating to an individual circuit. **IMPORTANT:** When using the Logic Connector Voltage Chart, voltage readings are referenced to pin 8. When using the Single Remote Display Voltage Chart, voltage readings are referenced to pin 3. When using the Dual Remote Display Voltage Chart, voltage readings for pins 1,2 and 4 are referenced to pin 3. Voltage readings for pins 5,6 and 8 are referenced to pin 7.

CHART 3 - LOGIC CONNECTOR VOLTAGE CHART

Logic Pin	Function	Normal Voltage Range	Comments
1	Sensor Brown	4.6 to 4.7 VDC	Sensor Connected
2	Sensor Black	2.3 to 2.4 VDC	Sensor Connected
3	Sensor Grey	0.14 to 0.16 VDC	Sensor Connected
4	Sensor Blue	0.06 to 0.08 VDC	Sensor Connected
5	Sensor White	14.2 to 14.4 VDC	Factory Adjusted
6	14 VDC Out	14.2 to 14.4 VDC	Factory Adjusted
7	Analog Out	0 to 5 VDC	Depends on flow
8	Analog Return	0 VDC	Ref. for Voltage Readings
9	Power Ground	0 VDC	
10	Power Ground	0 VDC	
11	Analog Out	0 to 5 VDC	Depends on flow
12	Event Out	0 VDC	No Alarm
		5 VDC	Alarm
13	Alarm Out	0 VDC	Not Connected
		Supply Voltage	Connected – No Alarm
		0 to 0.2 VDC	Connected – Alarm
14	24 VDC In	20 to 28 VDC	Varies with 24 V Supply

CHART 4 - SINGLE REMOTE DISPLAY VOLTAGE CHART

Remote Display Pin	Wire Color	Function	Normal Voltage Range
1	Red	Power	14.2 to 14.4 VDC
2	Green	Analog Flow	0.0 to 5.20 VDC
3	White	Analog Return	0.00 VDC
4	Black	Power Ground	0.00 to 0.30 VDC

CHART 5 - DUAL REMOTE DISPLAY VOLTAGE CHART

Remote Display Pin	Wire Color	Function	Normal Voltage Range
1	Red	Power	14.2 to 14.4 VDC
2	Green	Analog Flow	0.0 to 5.20 VDC
3	White	Analog Return	0.00 VDC
4	Black	Power Ground	0.00 to 0.30 VDC
5	Red	Power	14.2 to 14.4 VDC
6	Green	Analog Flow	0.0 to 5.20 VDC
7	White	Analog Return	0.00 VDC
8	Black	Power Ground	0.00 to 0.30 VDC

Sensor Test

The sensor may be tested using a digital multi-meter. It is not necessary to disconnect any wires. To obtain valid readings, the sensor must remain connected to its orange cable and the 14-pin connector must be unplugged from the logic unit. Connector pins 1 through 5 may then be probed using the connector's binding screws as test points. The table below gives acceptable ranges for the resistance readings. Readings outside of these ranges indicates a defective sensor. NOTE: Resistance readings between pins 1,2 and 3 will vary with temperature. This is normal and has been taken into account in the values given in the table. At room temperature (72 F, 22 C) these readings will be very close to 2.00 K ohms.

CHART 6 - SENSOR TEST CHART

Logic Pins	Wire Colors	Resistance Reading
1 – 2	Brown - Black	1.75 K to 2.35 K
2 – 3	Black - Grey	1.75 K to 2.35 K
1 – 3	Brown - Grey	1.75 K to 2.35 K
4 – 5	Blue - White	740 to 760 Ohms

Display Test

The display may be checked by disconnecting the sensor cable's brown wire from pin 1 on the 14-pin logic unit connector. This will cause the display to flash on the logic unit as well as the remote display, if installed. The alarm will also flash. This also tests the ability of the logic unit to detect a loss of continuity on one of the sensor wires. The same results may be obtained by disconnecting any one of the other sensor wires on pins 2 through 5 of the logic connector, or by disconnecting the cable at the sensor.

FIG. A - MODEL 612 - PARTS IDENTIFICATION

Logic Unit - Model 612
(Includes 14 pin plug)



Sensor Cable - 16 Ft.
57-6120-97



TEE
57-6120-04
thru
57-6120-09



Sensor Adapter
57-6120-98

Sensor
57-6120-99



Hose Clamps
(2 Required - Not Supplied)



Optional Remote Displays



Single Remote Display
57-A612-50



Dual Remote Display
57-A612-51

FIG. B - INSTALLATION OF ADAPTER INTO TEE

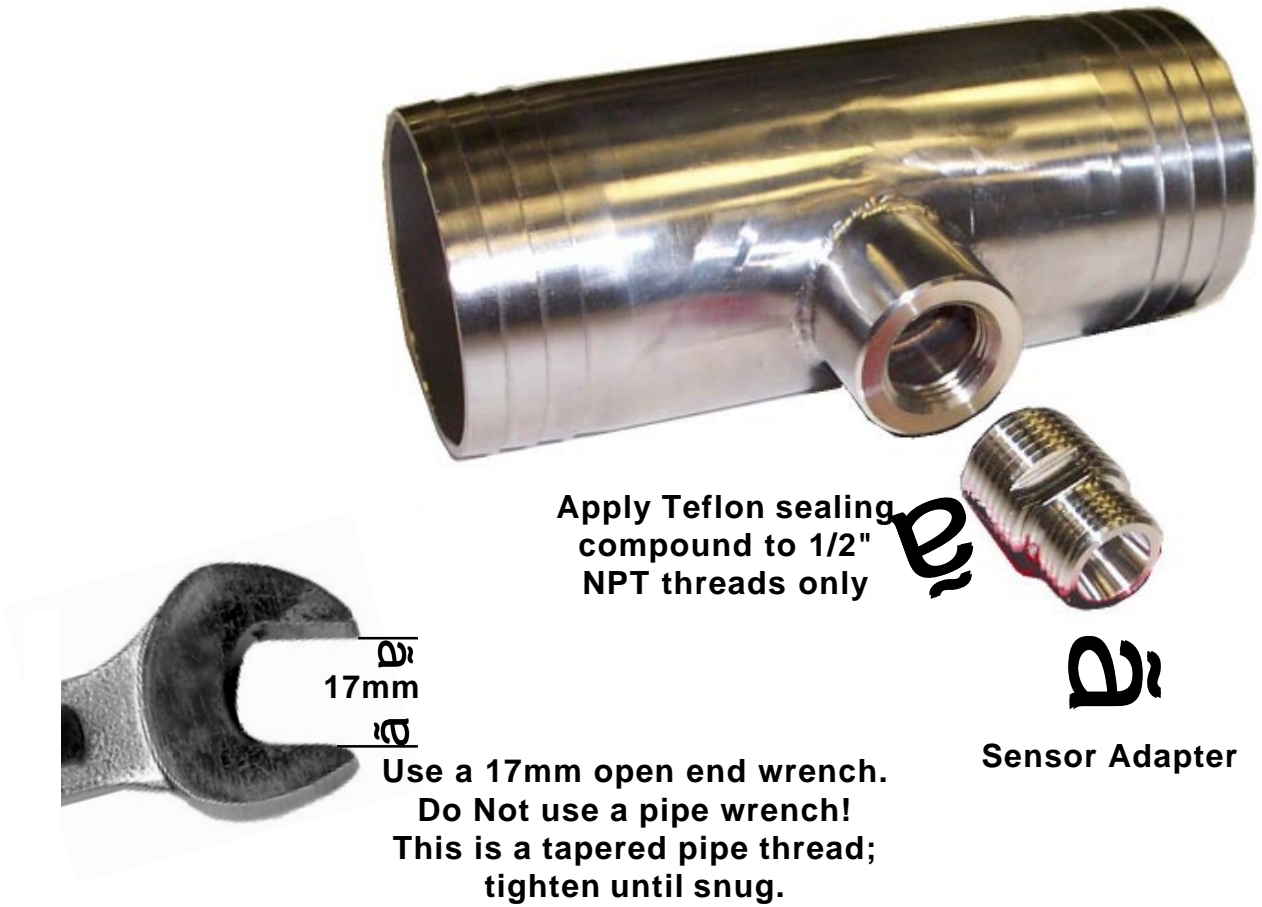

FIG. C - SELECTING A LOCATION FOR THE TEE

These minimum distances are necessary to avoid turbulent flow at the sensor; see chart on Page 3.

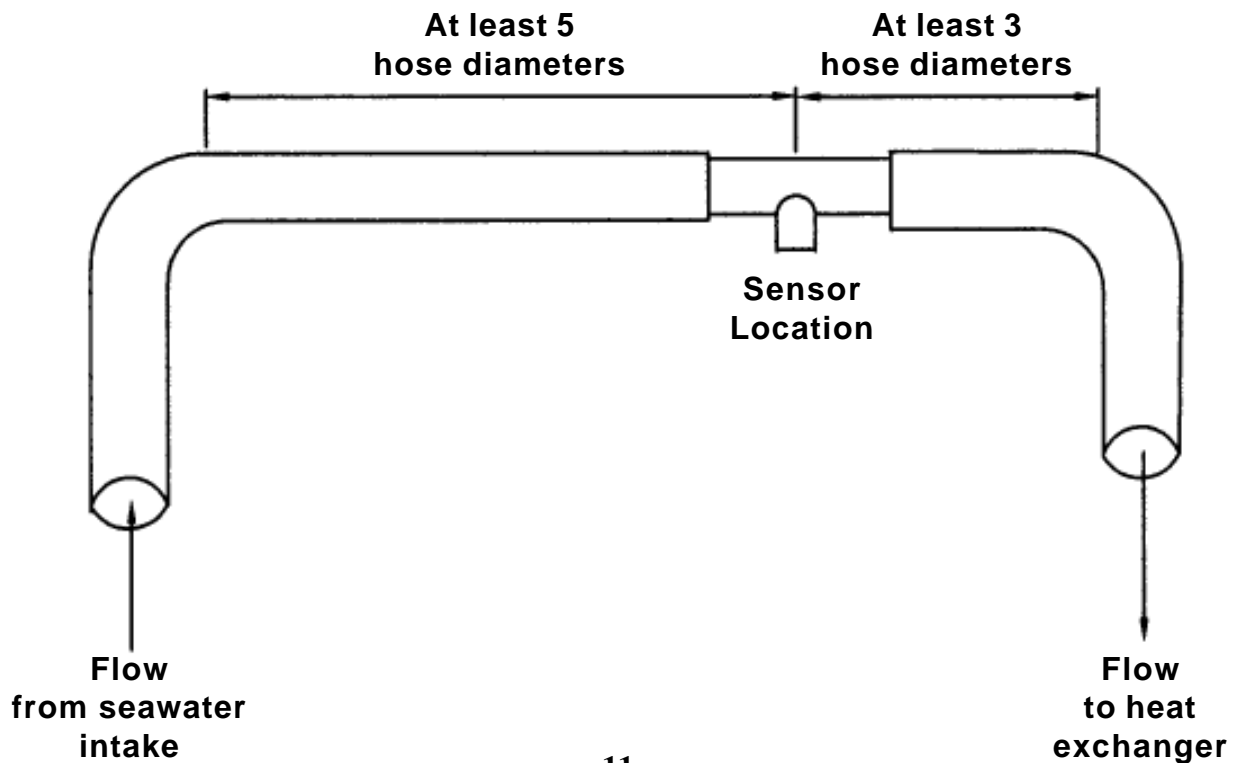

FIG. D - TEE MOUNTING POSITIONS

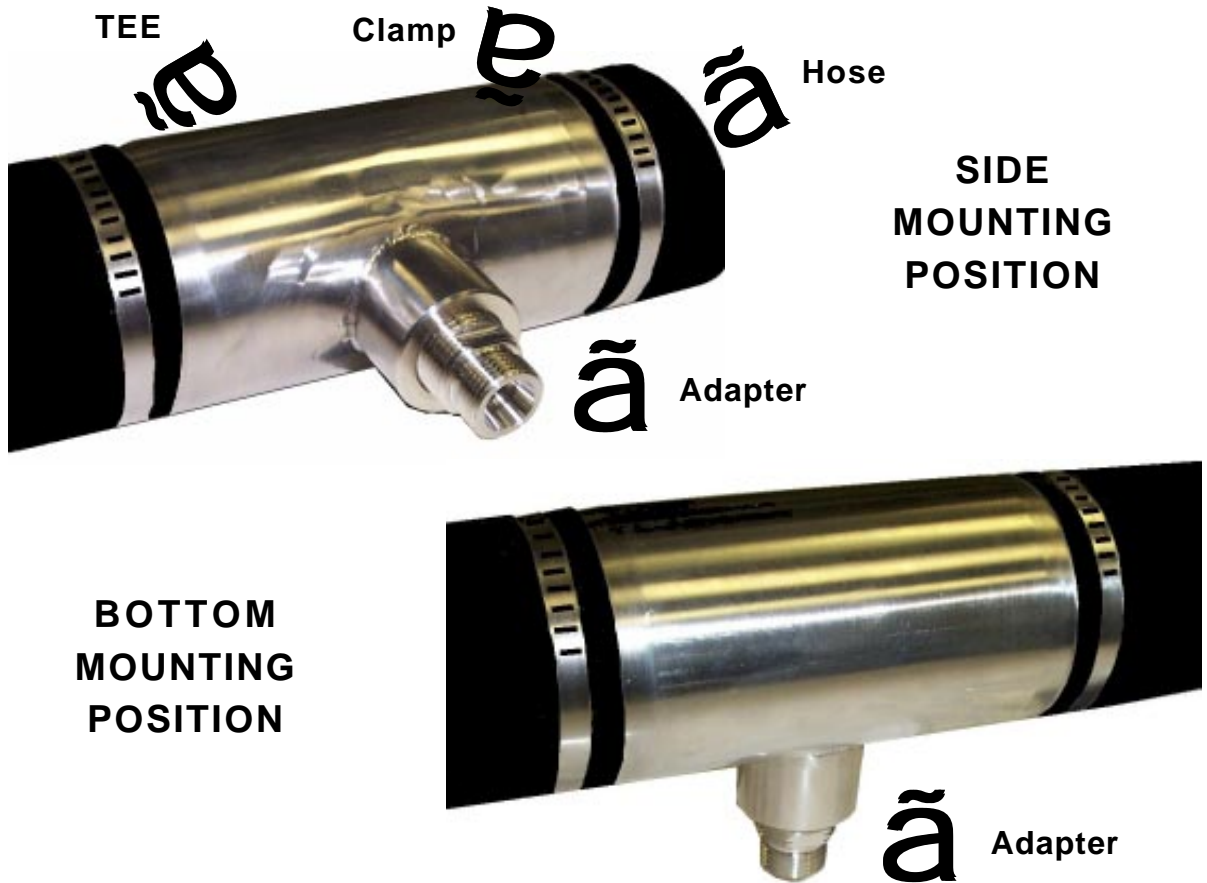

FIG. E - INSTALLING SENSOR INTO ADAPTER

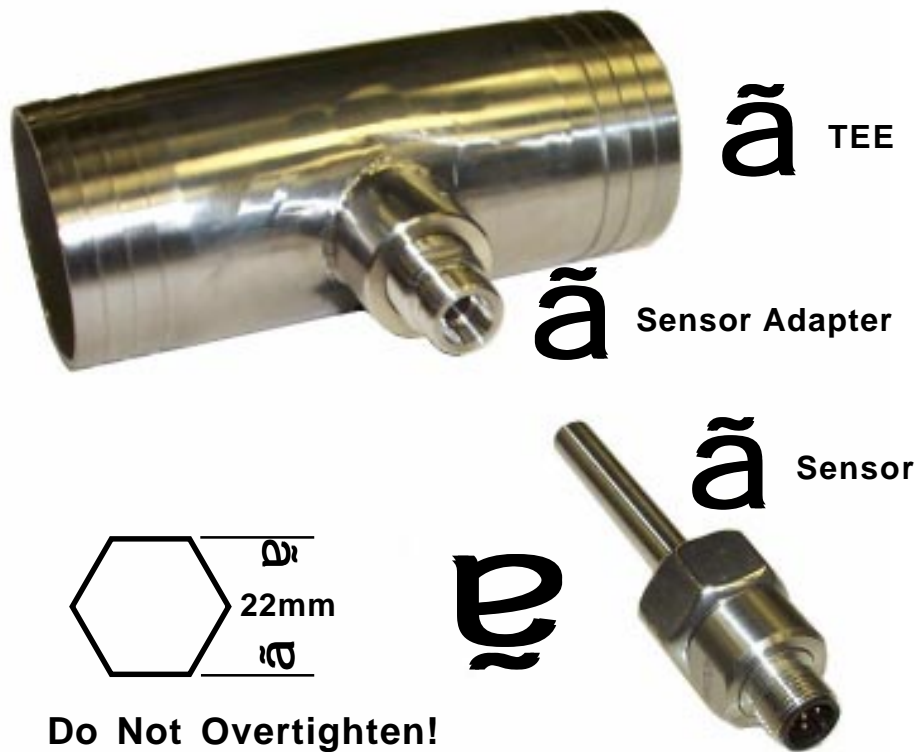

FIG. F - LOGIC UNIT WIRING DIAGRAM

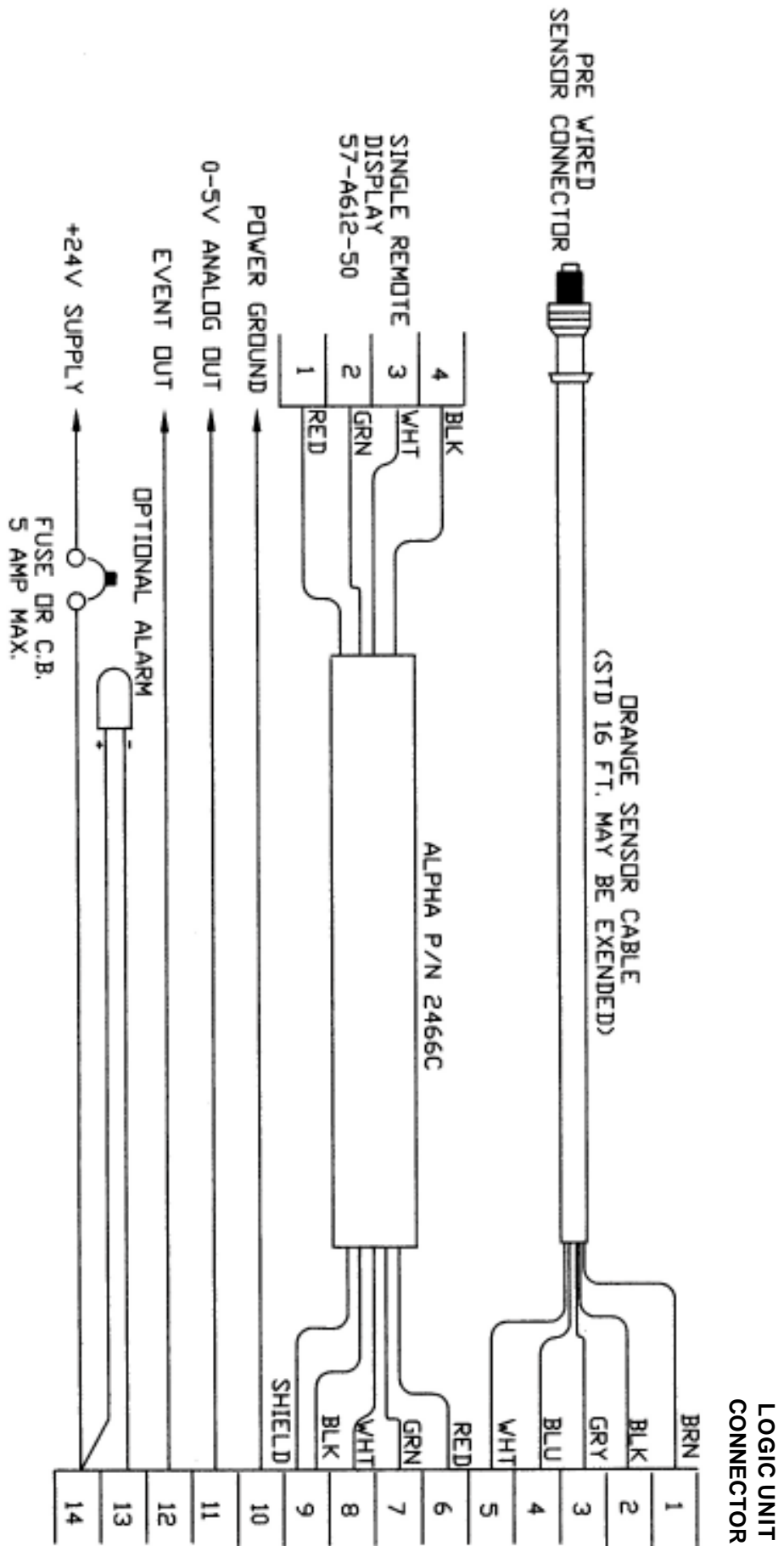

FIG. G - LOGIC UNIT WIRING DIAGRAM (W/ENGINE SAVER)

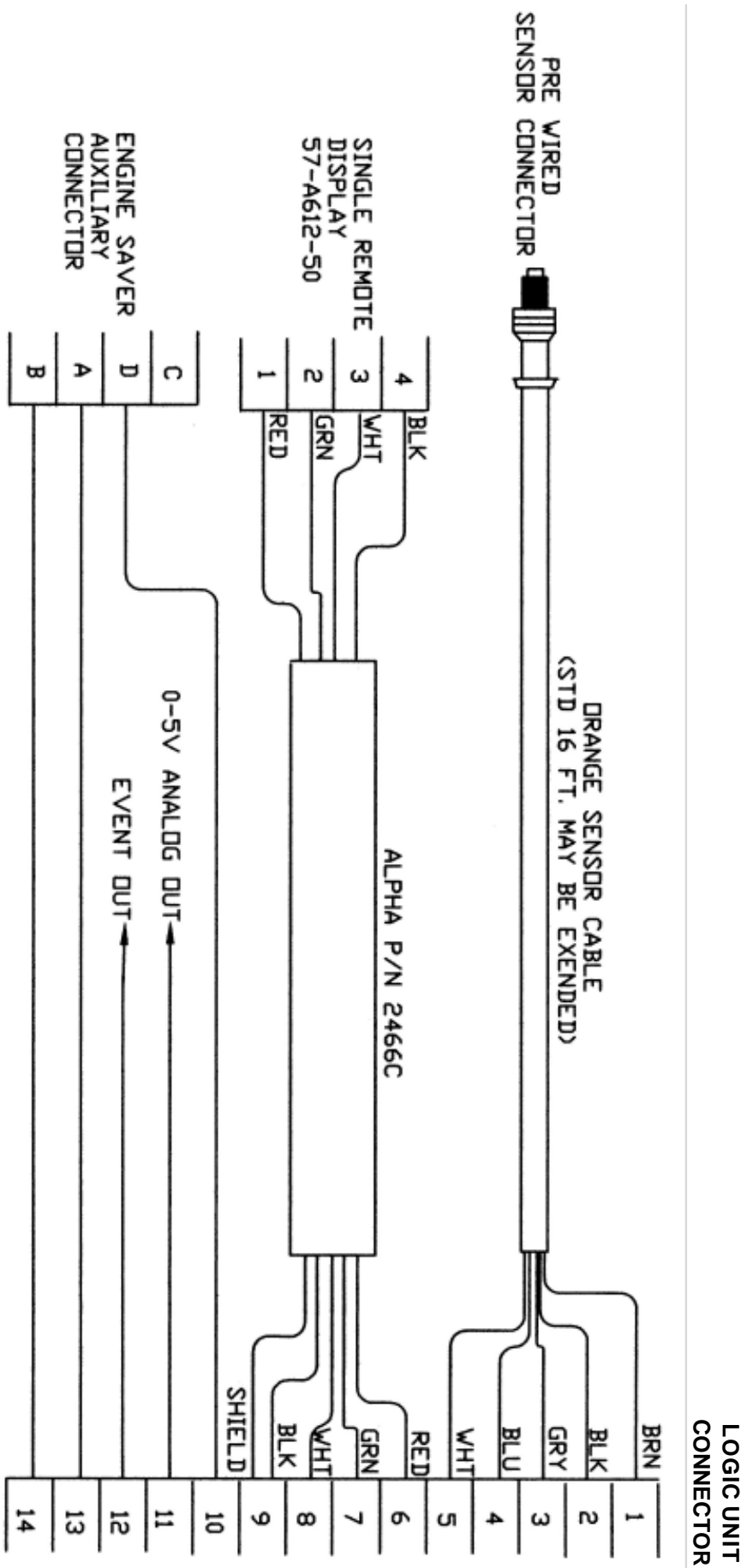

FIG. H - DUAL REMOTE DISPLAY WIRING DIAGRAM

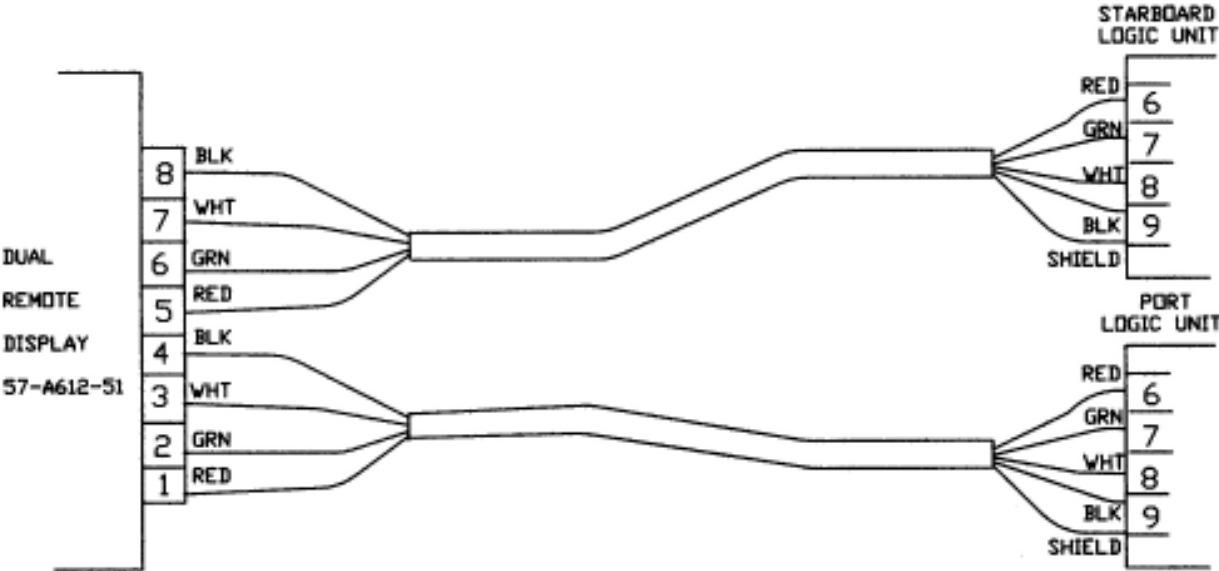
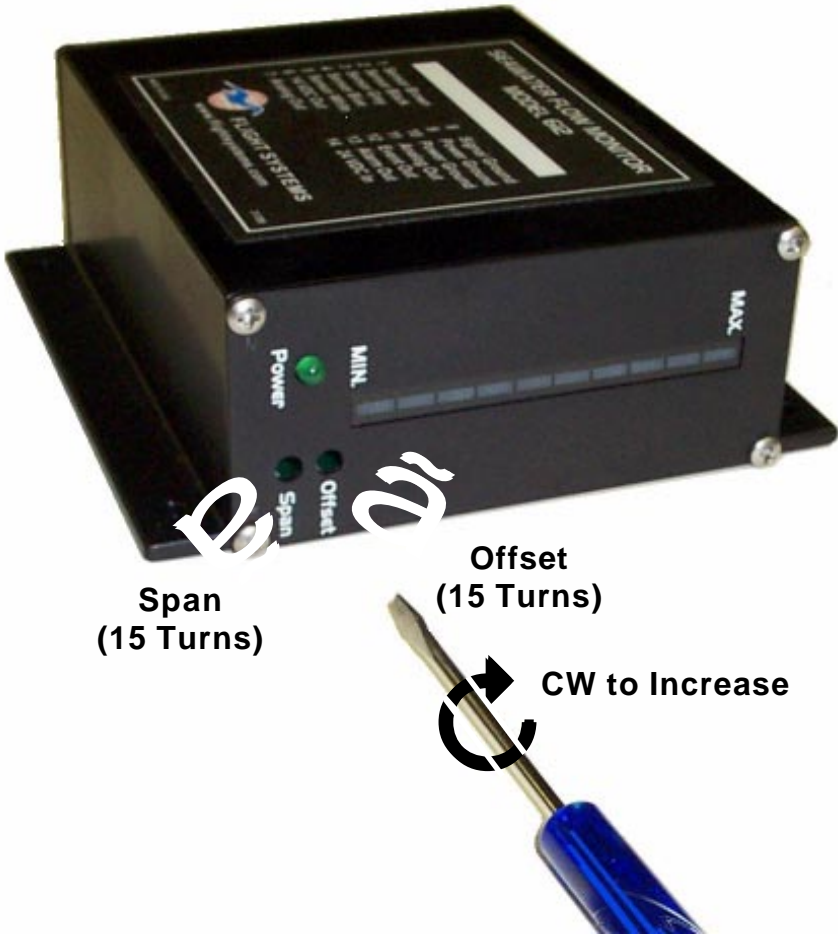
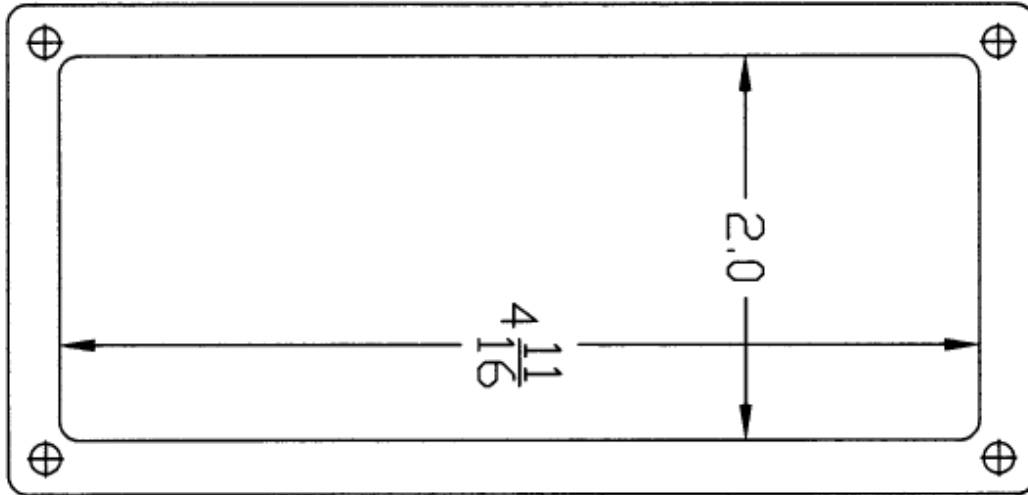

FIG. I - ADJUSTMENT OF SPAN AND OFFSET



**FIG. J - MOUNTING TEMPLATE FOR OPTIONAL
SINGLE REMOTE DISPLAY P/N 57-A612-50**



**NOTE: Minimum depth required behind
mounting surface for connector & wiring
is 1 1/2" (applies to either display)**

**FIG. K - MOUNTING TEMPLATE FOR OPTIONAL
DUAL REMOTE DISPLAY P/N 57-A612-51**

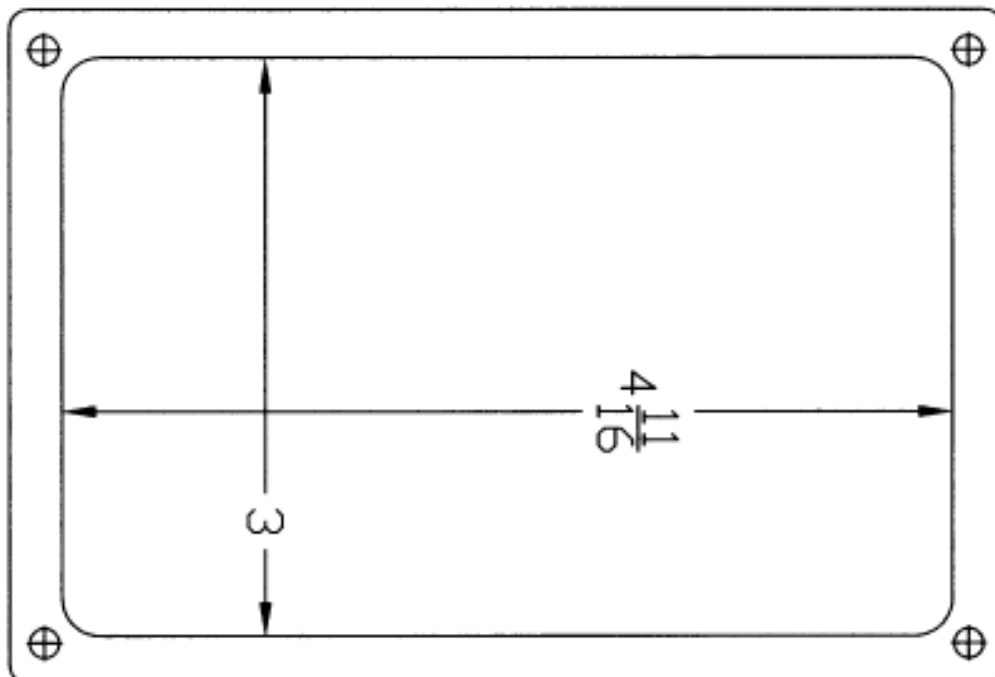
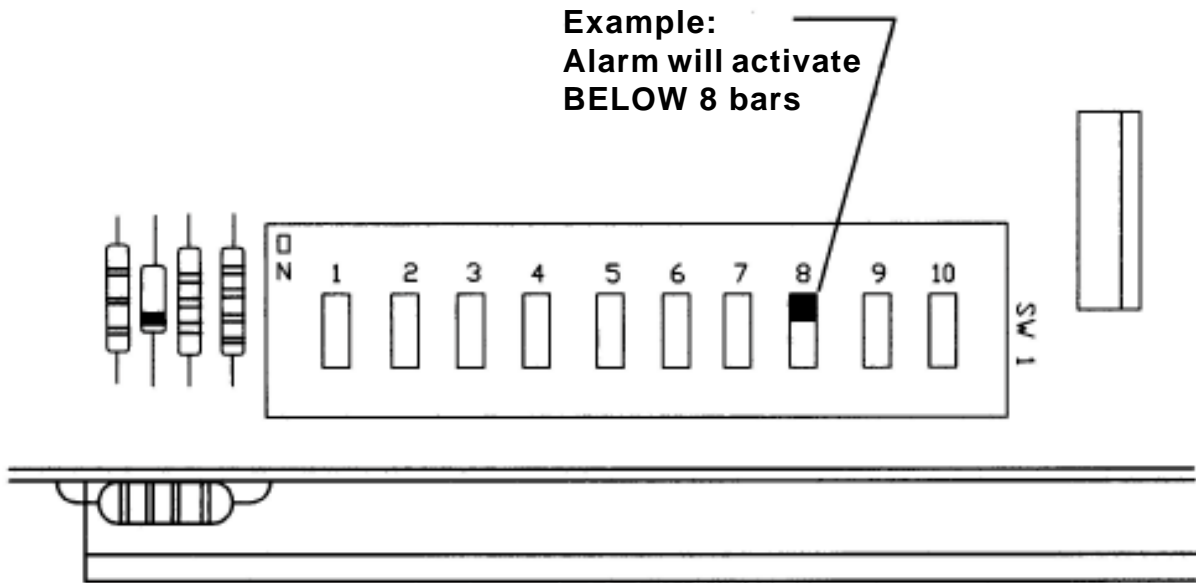

FIG. L - SETTING ALARM SWITCHES

Alarm will activate if no switches are on.

Turn on only ONE switch at a time.



**FIG. M - SYSTEM CONFIGURATION:
MODEL 612 SEAWATER FLOW MONITOR WITH SINGLE REMOTE**

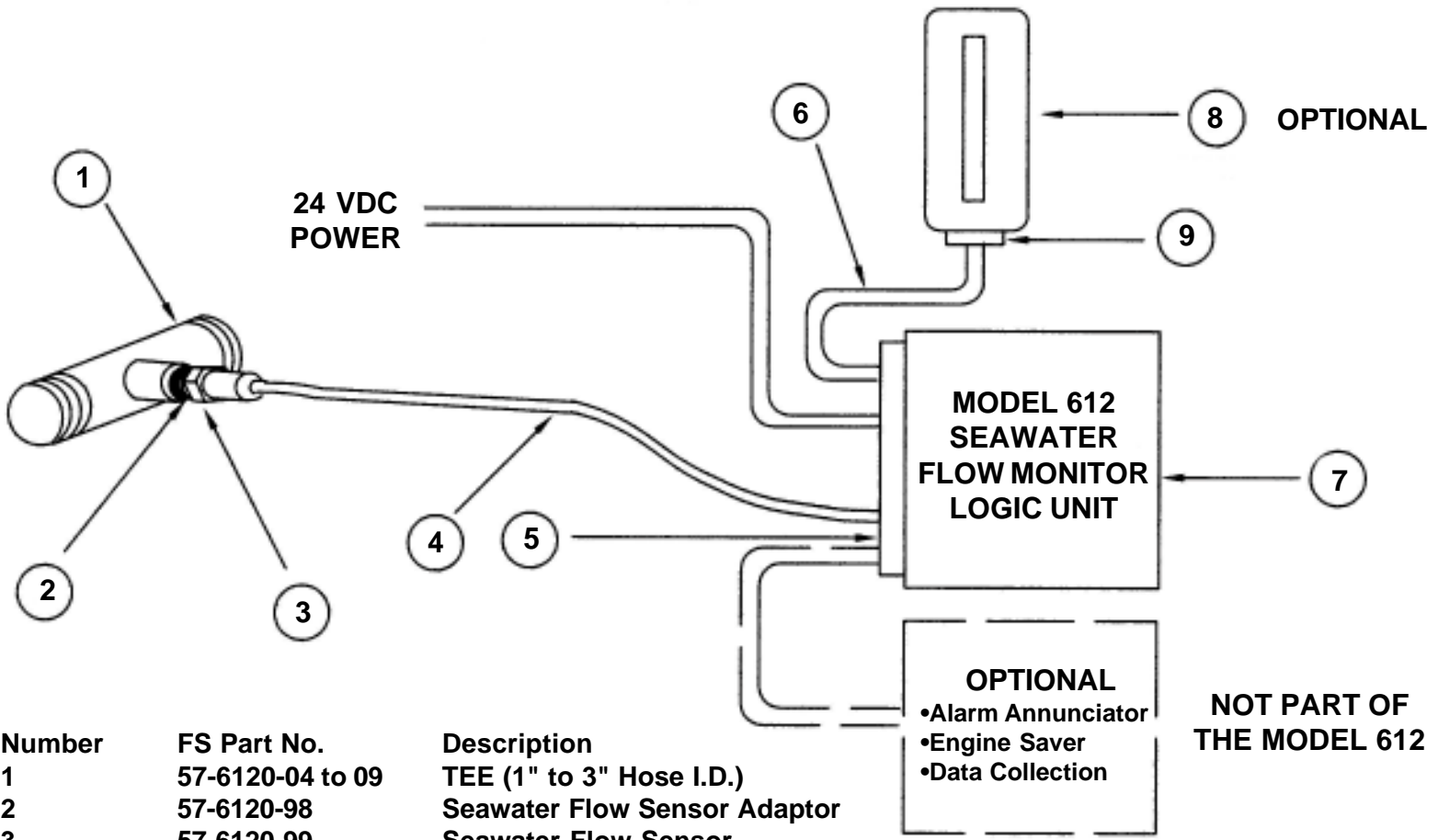

Number	FS Part No.	Description
1	57-6120-04 to 09	TEE (1" to 3" Hose I.D.)
2	57-6120-98	Seawater Flow Sensor Adaptor
3	57-6120-99	Seawater Flow Sensor
4	57-6120-97	Seawater Flow Sensor Cable 16'
5	57-6654-05	14 Pin Connector (Incl. w/ Logic Unit)
6	57-A612-64	Display Cable, Alpha Wire P/N: 2466C
7	612 Logic 24V	Seawater Flow Logic Unit
8	57-A612-50	Single Remote Display (Optional)
9	57-A612-10	4 Pin Connector (Incl. w/ Display)

OPTIONAL
 •Alarm Annunciator
 •Engine Saver
 •Data Collection

**NOT PART OF
THE MODEL 612**

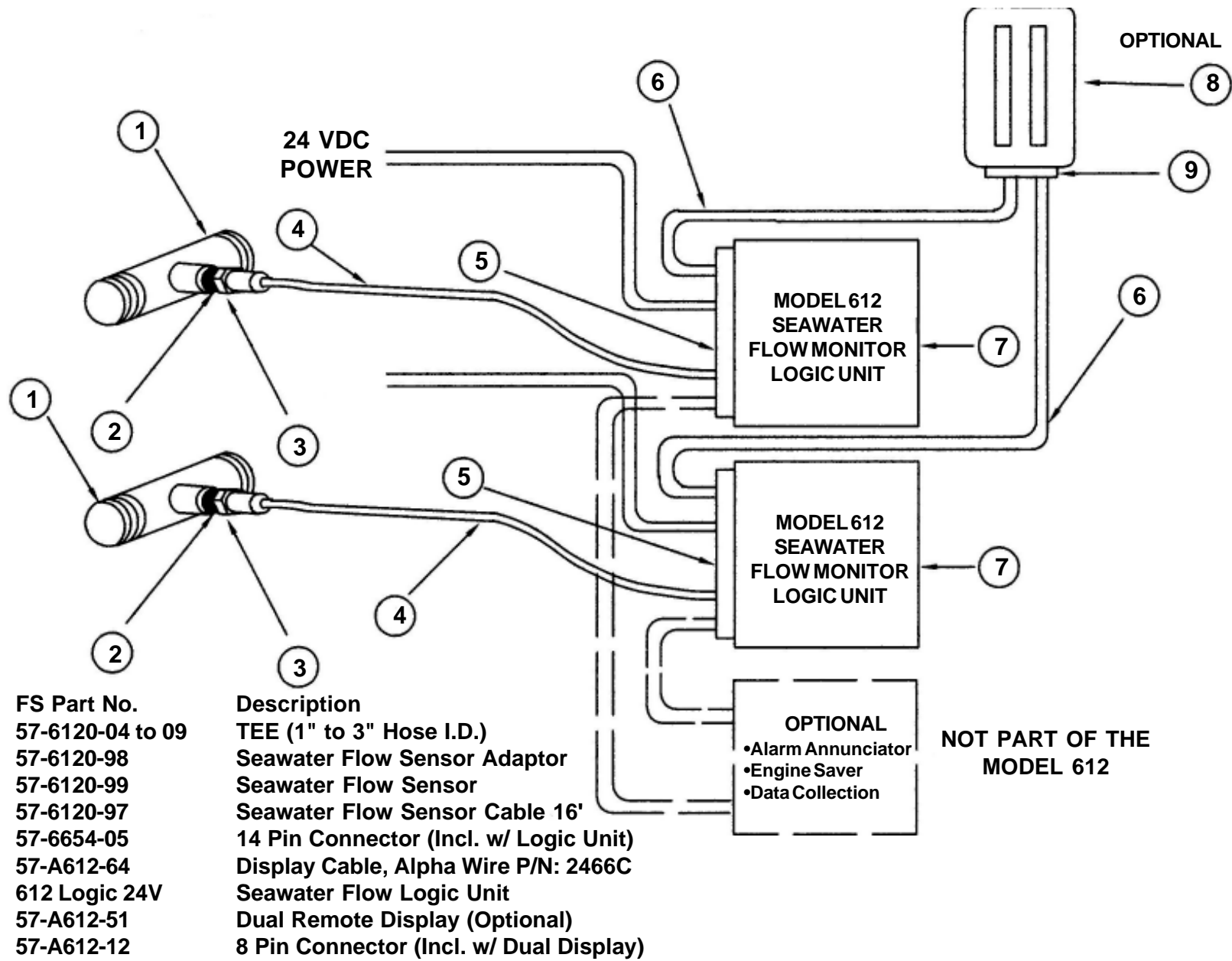

**FIG. N - SYSTEM CONFIGURATION:
MODEL 612 SEAWATER FLOW MONITOR WITH DUAL REMOTE**

NOT PART OF THE MODEL 612

OPTIONAL
•Alarm Annunciator
•Engine Saver
•Data Collection

24 VDC
POWER

MODEL 612
SEAWATER
FLOW MONITOR
LOGIC UNIT

MODEL 612
SEAWATER
FLOW MONITOR
LOGIC UNIT

OPTIONAL
•Alarm Annunciator
•Engine Saver
•Data Collection

OPTIONAL

PARTS LIST

Spare or replacement parts can be ordered through the manufacturer or distributors listed on the following page.

The Model 612 Seawater Flow Monitor is sold as a "Kit", which includes the Logic Unit, Seawater Flow Sensor, Sensor Adaptor & 16ft. Sensor Harness. Required Tee is sold separately - see below for available sizes.

One Stainless Steel Tee is Required for each Mod 612 Kit; 6 diameters available:

Tee Part #	Description
57-6120-04	S.S. Tee 1" O.D.
57-6120-05	S.S. Tee 1.25" O.D.
57-6120-06	S.S. Tee 1.50" O.D.
57-6120-07	S.S. Tee 2" O.D.
57-6120-08	S.S. Tee 2.50" O.D.
57-6120-09	S.S. Tee 3" O.D.

Replacement Parts:

Model 612	Logic Unit
57-6120-97	Seawater Flow 16ft. Sensor Harness
57-6120-98	Seawater Flow Sensor Adaptor
57-6120-99	Seawater Flow Sensor
57-9954-05	14 Pin Connector

Optional Remote Displays:

57-A612-50	Optional Single Remote Display (Used with single Model 612)
57-A612-51	Optional Dual Remote Display (Requires installation of 2 Model 612 Kits)
57-A612-64	Display Cable, Alpha Wire p/n 2466C (Specify 50, 85 or 125 foot length)

• Refer to Page 10 for photos of parts

REPAIR SERVICE / PARTS / TECHNICAL SUPPORT

The Model 612 Seawater Flow Monitor is fully rebuildable. Service, Parts and Technical Support can be obtained at various locations. (See previous page for a parts list.) Applications assistance is likewise available through the locations listed below.

SALES AND SERVICE LOCATIONS

NORTH AMERICA / CORPORATE HEADQUARTERS

FLIGHT SYSTEMS, INC. - *Manufacturing, Engineering, Technical Support and Spare Parts*
505 Fishing Creek Road
Lewisberry, PA 17339

Ph: 800-403-3728 / 717-932-9900
Fax: 800-333-9912 / 717-932-9925
www.flightsystems.com

Sales - Barry Ickes / Anthony Misiti
Engineering/Tech. Support - Bob York /
Ron Twietmeyer

USA / ON-SITE INSTALLATION and SERVICE

Gulf Coast / Southeast Atlantic Coast USA:

SAUNDERS ENGINE CO (Main Office)

PO Box 1824

Mobile, AL 36633

800-239-6551 / 251-456-4507 / Fax: 251-457-5563

www.saundersengine.com

David Brieler – Manager, Marine and Industrial Sales dbrieler@saundersengine.com

SALES REP. - Gulf Coast USA (Florida/Ala./Miss./Louisiana):

George W Gibbs IV

1414 Vista Cove Road

St. Augustine FL 32084-3036

904-810-5480 / Fax: 904-810-2330 E-Mail: ggibbsiv@bellsouth.net

Northeastern USA

RHODE ISLAND ENGINE CO. INC

79 State St. / PO Box 543

Narragansett, RI 02882-0543

401-789-1021 / Fax: 401-789-1066

Contact: Jay Gallup

WARRANTY INFORMATION

The **MODEL 612 SEAWATER FLOW MONITOR** is warranted to be free from defects in materials and workmanship for a period of two years from the date of shipment, or the date it is first put into service, if the latter is documented by completing and returning a copy of the **WARRANTY REGISTRATION** (On the following page) within *10 DAYS OF INSTALLATION*.

FLIGHT SYSTEMS' liability is limited to the repair or replacement of defective product within the warranty period, and does not cover installation or removal costs incurred or possible damage to other equipment (including engines or parts thereof) as a result of a malfunction of the **SEAWATER FLOW MONITOR**.

If, in the opinion of **FLIGHT SYSTEMS** (or its authorized agent) the malfunction of the **SEAWATER FLOW MONITOR** was caused by abuse, misuse or improper installation, the warranty claim will be disallowed and established repair rates shall apply.

Units should be shipped, freight charges prepaid, directly to **FLIGHT SYSTEMS, 505 Fishing Creek Rd, Lewisberry, PA 17339, USA**, or any of the authorized agents listed on the previous page.

NOTICE:

IN ORDER TO ACTIVATE YOUR WARRANTY, FILL OUT AND RETURN THE SEAWATER FLOW MONITOR WARRANTY REGISTRATION ON THE NEXT PAGE.

SEAWATER FLOW MONITOR WARRANTY REGISTRATION

Please fill out the information below and Fax or Mail to:
Flight Systems 505 Fishing Creek Road, Lewisberry, PA 17339 USA

PLEASE PRINT CLEARLY

COMPANY _____

ADDRESS _____

CITY _____ STATE _____ ZIP _____ COUNTRY _____

PHONE _____ FAX _____

CONTACT NAME _____ TITLE _____

E-MAIL _____

APPLICATION INFORMATION

DATE OF INSTALLATION _____

VESSEL NAME _____ TYPE _____

ENGINE _____ CONDITION _____ HOURS _____

ENGINE IS MAIN OTHER _____

INSTALLATION

INSTALLED BY: OEM DEALER FS AGENT/DIST OWNER/USER

COMMENTS:

This Form May be Faxed Toll-Free (USA & Canada) to:
800-333-9912 (International FAX: 717-932-9925)